

Operator's Manual for P7 Series Pistols

P7PSP, P7M8 & P7M13 9mm x 19
P7M10 Caliber .40 S&W

WARNING:

A firearm has the capability of taking your life or the life of someone else! Be extremely careful with your firearm. An accident can occur at any time and is almost always the result of not following basic safety rules.



HECKLER & KOCH

© Heckler & Koch, Inc.,
All rights reserved.
Heckler & Koch
7661 Commerce Lane
Trussville, Alabama USA
Telephone (205) 655-8299
www.hk-usa.com

Specifications and models subject to change without notice.
Revised March 2007

SAFETY RULES

Please read this operator's manual before handling your firearm. The following safety rules are placed in this manual by HKI as an important reminder that firearm safety is your responsibility. Firearms can be dangerous and can potentially cause serious injury, damage to property or death if handled improperly.

1. Never point a firearm at anyone or in any direction other than a SAFE direction; i.e., down range.
2. Treat all firearms as if they are always loaded.
3. Keep your finger off the trigger and outside of the trigger guard until your sights are aligned on the target and you are ready to fire.
4. Keep your finger off the trigger and outside of the trigger guard while loading or unloading the firearm.
5. Keep your finger off the trigger and outside of the trigger guard while pulling the firearm out of the holster or while returning it to the holster.
6. Be sure of your target and the backstop beyond.
7. Never give a firearm to or take a firearm from anyone unless the action is open and the magazine and/or chamber are free of any ammunition or brass.
8. Be sure that the ammunition you are using is factory loaded, is of the correct caliber for the firearm in which it is to be used, and that it is not damaged in any way.
9. Before firing, remove the magazine from the firearm, lock the action open, make sure the chamber is clear of any ammunition or brass, and check the barrel of the **unloaded** firearm for any possible obstructions.
10. Before firing any firearm that is unfamiliar to you, make sure that you understand exactly how it functions. A lack of familiarity with the firearm can result in a serious accident. Attend a certified training course on any firearm which you intend to use or with which you are not sufficiently familiar.
11. Always wear hearing and eye protection when using your firearm.
12. Keep all body parts, especially hands and fingers, away from the muzzle to avoid injury or burns.
13. Be sure that no part of either hand touches or interferes with the slide. The slide is moved backward by the recoil force of the pistol during firing and may cause serious injury.
14. Firearms should be stored separately from ammunition and beyond the reach of children and/or any untrained individuals.
15. Avoid the use of any alcoholic beverages or drugs before and during the use of any firearm.
16. Discharging firearms in poorly ventilated areas, cleaning firearms, or handling ammunition may result in exposure to lead; a substance known to be associated with birth defects, reproductive harm and other serious injury. Have adequate ventilation at all times. Wash hands thoroughly after exposure.

TABLE OF CONTENTS

Section 1	Introduction	4
Section 2	Function & Operation of the Weapon	5
	Action	5
	Cocking Lever	5
	Firing	6
	Grip	7
	Magazine	7
	Slide Catch Lever	8
	Magazine Release	9
	Sights	10
Section 3	Ammunition	11
Section 4	Loading & Handling	12
	Loading Magazine & Pistol	12
	Firing	13
	Reloading	14
	Unloading the P7 Pistol	14
	Unloading the PSP Pistol	15
Section 5	Field Stripping for Cleaning & Reassembly	16
	Disassembly	16
	Reassembly	17
	Removal of the Firing Pin - P7 Pistol	18
	Installation of the Firing Pin - P7 Pistol	19
	Removal of the Firing Pin - PSP Pistol	20
	Installation of the Firing Pin - PSP Pistol	20
Section 6	Cleaning & Maintenance	21
Section 7	Specifications	26
	Parts List - PSP Pistol	28
	Exploded View	29
	Parts List - P7M8 Pistol	30
	Exploded View	31
	Parts List - P7M13 & P7M10 Pistols	32
	Exploded View	33
	Service Record	34

SECTION 1

INTRODUCTION

HK P7 pistols can be drawn, cocked and fired accurately, faster than any other pistol. The unique HK design allows the P7 to be carried safely with a round in the chamber and the pistol completely uncocked. Cocking is accomplished quickly, without changing the firing grip and by depressing the cocking lever located on the front of the grip. As long as this lever is held fully depressed, the P7 fires and re-cocks like a conventional single-action pistol. Releasing the cocking lever decocks the P7 immediately and renders it completely safe.

P7 pistols have a constant, uniform trigger pull for rounds fired. There is no heavy first shot trigger pull like that found on a conventional double-action pistol. There is no change in trigger pull between critical first and second shots. A simple 3-dot sighting system makes aiming almost instinctive. All P7 pistols are completely ambidextrous.

To ensure accuracy, P7 pistols use a fixed polygonal barrel made by cold-hammer forging. Polygonal rifling seals propellant gases behind the bullet and increase barrel life. With its fluted chamber, the P7 will extract and eject an empty shell even if the extractor is missing. The extractor, which doubles as a loaded chamber indicator, only aids in making extraction smooth and uniform.

The P7 gas system retards the movement of the recoiling slide during firing and eliminates the need for a conventional locking mechanism or heavy slide. Combined with the optional grip angle of 110°, the result is an accurate, low recoil suited to the operational requirements of law enforcement users.

Using the potent .40 Smith & Wesson cartridge, the P7M10 was developed especially for law enforcement and civilian shooters searching for an effective combat handgun that fires a more powerful ammunition. Identical to P7 9mm pistols in operation, the strengthened P7M10 delivers ballistics approaching that of a .45 ACP pistol.

The PSP is very similar to the P7M8 with the only variation being the magazine release. All other functions are the same; however, some parts are not interchangeable between all P7 models. Service must be performed by a certified armorer at an authorized HK repair facility.

P7 pistols are available with corrosion resistant nickel plating or standard blued finished. The P7M13 carries 14 rounds, 13 rounds in the magazine plus 1 round in the chamber. The P7M10 carries 11 rounds, 10 rounds in the magazine plus 1 round in the chamber. The P7M8 and P7PSP-(P7M13) carry 9 rounds, 8 in the magazine plus 1 round in the chamber.

SECTION 2

FUNCTION AND OPERATION OF THE WEAPON

1. ACTION

HK P7 pistols are recoil operated pistols. However, upon ignition of the cartridge, a portion of the propellant gas flows through the gas port into the gas cylinder.

In the gas cylinder, the propellant gas acts upon the piston which retards the rearward motion of the slide until the bullet has left the barrel. Once the bullet has left the barrel, the decrease in gas pressure on the piston allows the slide to move rearward, ejecting the empty cartridge case. The recoil spring then moves the slide forward chambering the next round.

Advantages of this weapon design:

Stationary barrel, compact dimensions, uncomplicated components, no locking mechanism, reduced felt recoil.

WARNING: DO NOT USE REMANUFACTURED AMMUNITION OR RE-LOADED AMMUNITION. NEVER USE AMMUNITION WITH LEAD BULLETS WHICH CAN CAUSE EXCESS FOULING OF THE GAS SYSTEM CAUSING MALFUNCTIONS. USE ONLY JACKETED FACTORY MANUFACTURED AMMUNITION. P7 PISTOLS SAFELY FUNCTION WITH ALL FACTORY BRANDS OF JACKETED HOLLOW POINT AMMUNITION.

2. COCKING LEVER

All P7 pistols use a unique safety system which differs from those normally found in other single or double-action pistols. The system design eliminates the need for a separate manually operated safety. When the shooter grips the pistol with sufficient pressure to activate

the cocking lever, he/she simultaneously and automatically cocks the pistol.

Now the weapon is ready to be fired via the trigger in single action mode. The single-action mode of firing is not only faster, but also more accurate. Once the pistol is cocked, it is only necessary to maintain a force of approximately 1.5 pounds on the cocking lever to keep the system ready to fire. Should the cocking lever be released, the pistol will be automatically uncocked, rendering it safe. As long as the cocking lever is depressed, the trigger operates in single-action mode. This provides for a conveniently short pull and a moderate force required to operate the trigger.

Should the shooter inadvertently drop the weapon, it will automatically and completely uncock itself. In addition, the drop safety will be engaged preventing the firing pin from hitting the primer. This design eliminates the need for a firing pin system actuated by a hammer. It also eliminates the need for an additional external safety device.

As a third function, the cocking lever releases the slide catch when the slide is locked to the rear. Moderate pressure on the cocking lever is all that is needed to close the slide. This action will simultaneously chamber a round if a loaded magazine has been inserted.

Thus the three functions of the cocking lever are:

- a) To cock the pistol
- b) To act as a safety device
- c) To release the slide

The design also makes all P7 pistols truly ambidextrous.

ALL HK P7 PISTOLS CAN BE FIRED IN THREE DIFFERENT WAYS:

- a) Depressing the cocking lever and then pulling the trigger (preferred method) – single action.
- b) Pulling the trigger and then depressing the cocking lever – double action.
- c) The cocking lever is depressed and the trigger is pulled simultaneously.

Due to these features, the P7M8/M13/M10 should function under

normal conditions even if the shooter does not carry out all operations in the correct sequence. Also, the pistol can be fired with the magazine removed.

3. GRIP

The pistol grip is angled 110° first relative to the barrel, which is the same angle the index finger forms to the fist when pointed. This angle allows better target acquisition and facilitates instinctive shooting. Despite the 110° angle, the magazine is almost perpendicular to the barrel, providing optimum feed of cartridges from the magazine to the chamber.

This design makes the pistol less susceptible to malfunctions, regardless of the type of ammunition used – hollow point (HP), full metal case or soft-nose bullets.

4. MAGAZINE

The P7M8 and P7PSP uses a single column magazine, which holds a total of 8 rounds. The magazine has numbered holes on the sides allowing visual counting of the cartridges.

P7M13 and P7M10's use a double-row magazine that tapers to a single row so that the cartridges are fed from the center of the magazine. This magazine has two slots on the left side indicating the number of rounds loaded.

Both magazines are designed to provide maximum reliability and durability.

WARNING: DO NOT ATTEMPT TO LOAD MORE THAN THE PRESCRIBED NUMBER OF ROUNDS INTO THESE MAGAZINES. DO NOT ALTER THE SHAPE OF THE MAGAZINE HOUSING OR THE FOLLOWER. DO NOT LENGTHEN OR ALTER MAGAZINE SPRING. TO DO SO MAY CAUSE MALFUNCTION OF THE SYSTEM OR THE MAGAZINE MAY NOT SEAT OR FEED PROPERLY.

The slide catch lever is employed for keeping the action open without a magazine being inserted.



5. SLIDE CATCH LEVER

The P7 pistols incorporate a slide catch lever located on the left side of the frame behind the trigger. This lever is integrated into a recess of the frame so that it does not interfere with the shooter, regardless of whether he/she is right or left-handed.

To lock the slide to the rear, press the slide catch lever rearward with either the forefinger or thumb of the shooting hand while pulling the slide rearward until it locks.

Ensure that the muzzle of the pistol is pointed in a safe direction at all times and that the finger is kept out of the trigger guard.

The slide catch lever can be disengaged by either depressing the cocking lever or by pulling the slide slightly farther to the rear and releasing it.

Pull back slide:
Press in projecting slide catch lever in direction of arrow.
EITHER ▼ OR ▼



6. MAGAZINE RELEASE

P7M8/P7M13/P7M10 magazine release levers are located on both sides of the frame just to the rear of the trigger guard. They can be used with equal ease by both left and right-handed shooters by pressing the levers downward with either the thumb or index finger of the shooting hand.

PRESS MAGAZINE CATCH DOWN ▼



7. P7PSP MAGAZINE RELEASE

The P7PSP magazine release is located at the base of the frame. Press the magazine release forward and extract the magazine.



8. SIGHTS

The sighting system on the P7 pistols is a 3-dot sighting system. By aligning all 3 dots horizontally on the target, the shooter has an extremely quick target acquisition under most lighting conditions.

The rear sight can be adjusted for windage by loosening the set screw, moving the sight to the right or left depending on the desired shot placement, and re-tightening of the set screw.

Adjustment for elevation is accomplished by interchangeable front sights with different heights. To do so, the front sight pin must be removed. The height of the front sight is indicated on the underside.

P7 pistols are designed for single-handed ambidextrous operations.

SECTION 3

AMMUNITION

AMMUNITION WARNING: HKI SPECIFICALLY DISCLAIMS ANY RESPONSIBILITY FOR ANY DAMAGE OR INJURY THAT SHOULD OCCUR BECAUSE OF OR AS A RESULT OF THE USE OF FAULTY, REMANUFACTURED, OR RELOADED AMMUNITION (HAND LOADED), OR OF CARTRIDGES OTHER THAN THOSE FOR WHICH THESE PISTOLS WERE ORIGINALLY CHAMBERED IN THE P7M8 AND P7M13 9MM X 19, ALSO KNOWN AS 9MM LUGER OR 9MM PARABELLUM FOR PISTOLS.

The HK P7 pistols are designed to fire quality, factory-loaded, JACK-ETED ammunition including jacketed hollow point ammunition, having a bullet weight of at least 100 grains.

WARNING: THE USE OF LEAD BULLETS WILL CAUSE MALFUNCTIONS DUE TO EXCESS FOULING OF THE GAS SYSTEM.

CAUTION: THERE IS AN INFLUX OF SURPLUS 9MM X 19 AMMUNITION ON THE AMERICAN MARKET. DO NOT USE 9MM X 19 AMMUNITION SPECIFICALLY LOADED FOR SUBMACHINE GUNS.

The following guidelines should be considered when selecting the correct ammunition for your pistol:

1. Be sure the ammunition you have chosen is compatible with your weapon – proper caliber, bullet weight.
2. Prior to loading the magazine and chamber, carefully inspect all cartridges for the following abnormalities:
 - a. Cracked or split cases
 - b. Improperly seated bullets and primers
 - c. Damaged bullets

IMPROPERLY LOADED AMMUNITION CAN CAUSE DAMAGE TO THE PISTOL AND/OR INJURY TO THE SHOOTER OR BYSTANDERS.

3. Do not attempt to fire a round in which the projectile has been forced back into the case. This condition, upon firing, may result in increased chamber pressure above safe limits.

SECTION 4

LOADING AND HANDLING OF THE P7 PISTOLS

1. LOADING MAGAZINE

Hold the magazine in one hand with the thumb sitting on top of the lips. With the other hand, place a round on the follower in front of the lips and press down and to the rear. For easier loading, place the thumb of the hand holding the magazine on the rim of the cartridge and apply pressure on the cartridge while pushing the cartridge into the magazine. To insert subsequent rounds, press down on the cartridge already in the magazine with your thumb and repeat the process.

2. LOADING OF THE PISTOL

CAUTION: DO NOT PLACE YOUR FINGER ON THE TRIGGER UNTIL YOU ARE READY TO FIRE.

2.1 Loading with the slide forward:

Place the loaded magazine completely into the magazine well and ensure that the magazine catch engages properly.

Always have the muzzle of the pistol pointed in a safe direction, keeping the finger off the trigger. Pull the slide all the way to the rear and release it to load the chamber.

2.2 Loading with slide locked to rear:

- a) Insert a loaded magazine fully into the magazine well and depress the cocking lever to chamber a cartridge.
- b) Insert a loaded magazine fully into the magazine well and pull the slide slightly further to the rear and let the slide snap forward. To chamber silently, lead the slide forward.
- c) Release the cocking lever to make the pistol "Safe."

CAUTION: WHEN LOADING THE PISTOL WITH THE SLIDE LOCKED TO THE REAR, BE SURE THAT YOUR FINGER IS NOT ON THE TRIGGER. DEPRESSING THE COCKING LEVER TO RELEASE THE SLIDE ALSO COCKS THE FIRING PIN.

To fully load your pistol, remove the magazine and insert one more cartridge into it. Place the magazine back into the pistol completely to ensure catch engagement. Your P7 is now loaded to capacity – 9 rounds in the P7M8 and P7PSP, 14 in the P7M13, and 11 in the P7M10.

Filling the magazine ▼



Pull back slide ▼



3. FIRING THE P7M8/P7M13/P7M10 PISTOLS

To fire the loaded pistol, depress the cocking lever which will cock the firing pin. Align the sights onto the target and pull the trigger, releasing the cocked firing pin. Keep the cocking lever depressed for all subsequent shots.

NOTE: ONCE THE WEAPON HAS BEEN COCKED USING THE COCKING LEVER, THE SHOOTER CAN RELAX THE GRIP AND HOLD THE PISTOL WITH ONLY THE FORCE REQUIRED TO HOLD A CONVENTIONAL PISTOL.

To render the pistol immediately uncocked, release the cocking lever.

CAUTION: DO NOT PLACE YOUR FINGER ON THE TRIGGER UNTIL YOU ARE READY TO FIRE.

4. RELOADING WHEN THE MAGAZINE IS EMPTY

After the last round has been fired, the slide will remain open. To continue firing, simply exchange the empty magazine for a full one. Depress the cocking lever chambering a new round. The pistol now is ready to fire again.

CAUTION: DO NOT PLACE YOUR FINGER ON THE TRIGGER UNTIL YOU ARE READY TO FIRE.

5. UNLOADING THE P7 PISTOL

The following steps should be taken when unloading your pistol:

- Keep muzzle pointed in a safe direction and finger off the trigger.
- Remove the magazine by pressing one of the magazine release levers downward.
- Pull the slide to the rear, which will eject any chambered round.
- Lock the slide to the rear by means of the slide catch lever.
- Inspect the chamber to ensure the pistol is cleared.
- Store pistol in a safe place away from children. (It is not necessary to store the pistol with the slide in the rearward position.)

Cocking lever depressed ▼



CAUTION: DO NOT PLACE YOUR FINGER ON THE TRIGGER UNTIL YOU ARE READY TO FIRE.

5. UNLOADING THE PSP PISTOL

The following steps should be taken when unloading your pistol:

- Keep muzzle pointed in a safe direction and finger off the trigger.
- Press magazine catch forward and extract magazine.
- Pull the slide to the rear, which will eject any chambered round.
- Inspect the chamber to insure the pistol is cleared.
- Let slide snap forward again.
- Store pistol in a safe place, away from children. (It is not necessary to store the pistol with the slide in the rearward position.)

Press magazine catch forward ▼



SECTION 5

FIELD STRIPPING OF THE P7 FOR CLEANING AND REASSEMBLY

A. FOR FIELD STRIPPING, THE FOLLOWING STEPS SHOULD BE CARRIED OUT:

1. Keep muzzle pointed in a safe direction and finger off the trigger.
2. Remove magazine.
3. Pull the slide to the rear and lock the slide in rearward position.
4. Inspect the chamber to ensure that the pistol is clear.
5. Let the slide snap forward.
6. Press the slide-retaining button located on the rear left side of the receiver while pulling the slide approximately 3/4" to the rear and lift up.
7. Remove the slide toward the muzzle. Be careful to lift the slide enough as to not strike the barrel with the breech face.
8. Remove the recoil spring.

Press slide retainer and pull back slide ▼



ASSEMBLIES

1. Slide
2. Receiver
3. Magazine

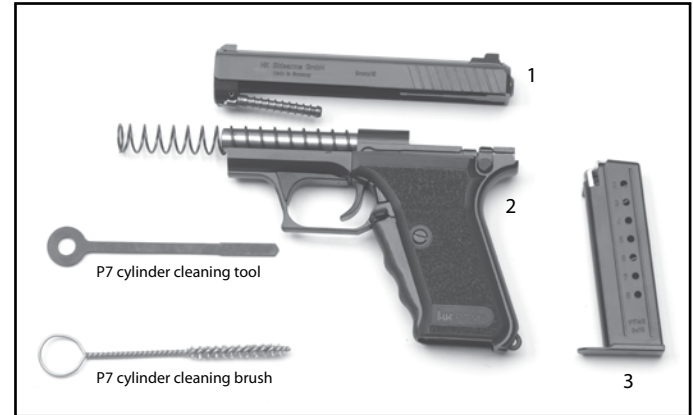

B. REASSEMBLING THE P7

1. Mount recoil spring onto the barrel.
2. Place the slide in a slightly angled position over the receiver making sure that the gas position is aligned with the gas cylinder.
3. Slowly pull the slide full rearward over the barrel against the force of the recoil spring.
4. Press the slide down and let it move forward while still applying slight pressure on the slide.
5. Manually operate the slide to ensure proper function.

NOTE: DIFFICULTY IN REASSEMBLY CAN USUALLY BE ATTRIBUTED TO MISALIGNMENT OF THE PISTON AND CYLINDER OR BINDING OF THE RECOIL SPRING IN THE FORWARD PORTION OF THE SLIDE.

Place the slide on the receiver ▼



Push the firing pin bushing forward and rotate ▼



C. REMOVAL AND INSTALLATION OF THE FIRING PIN ASSEMBLY AND BUSHING

CAUTION: BEFORE REMOVAL OF THE FIRING PIN ASSEMBLY AND BUSHING, REMOVE THE MAGAZINE AND ENSURE THAT YOUR WEAPON IS UNLOADED.

1. REMOVAL OF THE FIRING PIN ASSEMBLY AND BUSHING

- a) Depress cocking lever until the end of the firing pin is flush with the slot in the firing pin bushing.
- b) Push the firing pin bushing with your thumb or a suitable coin all the way forward and rotate 90° clockwise (to the right).

- c) Depress cocking lever fully and remove the firing pin bushing together with the firing pin assembly.

NOTE: THE FIRING PIN BUSHING CAN ONLY BE REMOVED WHEN THE SLIDE IS MOUNTED ON THE RECEIVER. DO NOT USE EXCESSIVE FORCE TO TURN THE BUSHING.

2. INSTALLATION OF THE FIRING PIN ASSEMBLY AND BUSHING

CAUTION: FURTHER DISASSEMBLY OF THE FIRING PIN IS NOT RECOMMENDED; HOWEVER, IF FOR ANY REASON THE FIRING PIN ASSEMBLY IS FURTHER DISASSEMBLED, CARE MUST BE TAKEN THAT THE FIRING PIN COLLAR PIN IS CORRECTLY SEATED IN THE SLOTS OF THE FIRING PIN COLLAR. IMPROPER ASSEMBLY MAY CAUSE MALFUNCTION.

- a) Insert firing pin assembly and bushing into the slide end until the chamber of the firing pin bushing is even with the slide end.
- b) Rotate the firing pin bushing 90° counterclockwise (to the left) until it engages its slot in a vertical position.

Collar pin seating ▼



3. REMOVAL AND INSTALLATION OF THE FIRING PIN FOR THE PSP PISTOL

REMOVAL

- a) Depress squeeze cocker until the firing pin is even with the rear of the slide.
- b) Press bush approximately 0.02 inches (0.5mm) forward with the special screwdriver and rotate 90° to the right.
- c) Depress squeeze cocker all the way and remove firing pin.

INSTALLATION

- a) Insert firing pin into the slide until the bush is located approximately 0.02 inches (0.5mm) inside the slide.
- b) Rotate bush 90° to the left until it engages and is even with the rear end of the slide.

SECTION 6

CLEANING AND MAINTENANCE

The service life and performance of your pistol depend upon correct handling and proper care.

A. AFTER EVERY SHOOTING, THE FOLLOWING PROCEDURE IS RECOMMENDED FOR CLEANING:

1. Field strip the pistol.
2. Remove visible dirt, moisture and propellant residue.
3. Clean the barrel thoroughly using a brass or nylon brush.
4. Bright parts must be wiped cleaned.
5. To clean the slide, no hard tools must be used. It is recommended to use an oil soaked cloth or a soft bristle brush. Otherwise, the drop safety catch spring could be disengaged and the function of the drop safety could consequently be impaired.
6. To clean the gas piston, use only a soft oil soaked cloth or patch.

NOTE: DO NOT USE HARD INSTRUMENTS, BRUSHES OR STEEL WOOL, ETC. FOR CLEANING OF THE GAS PISTON. DISCOLORATION AND SMALL AMOUNTS OF RESIDUE ARE NORMAL AND WILL NOT EFFECT THE FUNCTION OF THE PISTOL. THEREFORE, THEY NEED NOT BE REMOVED.

7. Oil the pistol parts lightly after cleaning, including the bore.

NOTE: CHECK DROP SAFETY CATCH AND SPRING VISUALLY FOR ENGAGEMENT.

8. Reassemble the pistol.

B. AFTER FIRING APPROXIMATELY 500 ROUNDS, DEPENDING ON THE TYPE OF AMMUNITION USED, OR ONCE EVERY 12 MONTHS - WHICHEVER HAPPENS FIRST - THE FOLLOWING CLEANING PROCEDURE IS RECOMMENDED:

1. Field strip the pistol including the firing pin assembly and bushing.
2. Remove the grip plates by first unscrewing and removing the grip screws. Then lift forwardmost end of the grip plates away from the frame and slide forward.

NOTE: DO NOT USE TOOLS OR EXCESSIVE FORCE TO LIFT GRIP PLATES.

3. Remove all dirt, moisture and carbon on all exposed parts. To do so, it is recommended to use a solvent or gun oil and a soft brush.
4. To clean the bottom of the gas cylinder, use the P7-cleaning tool.
 - 4.1 Insert the cleaning tool in the gas cylinder.
 - 4.2 Turn the P7 cleaning tool in a clockwise direction until you reach the bottom of the cylinder.
 - 4.3 Remove the P7 cleaning tool in a clockwise direction until you reach the bottom of the cylinder.
 - 4.4 Repeat step 4.1 through 4.3.

CAUTION: DO NOT USE REAMER, DRILL BITS OR OTHER HARD TOOLS TO CLEAN GAS CYLINDER. THIS MIGHT DAMAGE THE GAS CYLINDER CAUSING A MALFUNCTION OF THE PISTOL.

P7 and P7 cylinder cleaning tool ▼



P7 cylinder cleaning tool inserted in the gas cylinder ▲

5. To clean the cylinder wall, use the P7 cleaning brush with a small amount of solvent or gun oil.
 - 5.1 Turn the P7 cleaning brush into the entire length of the gas cylinder.
 - 5.2 Remove the P7 cleaning brush.
 - 5.3 Turn muzzle downward.
6. Clean the slide thoroughly. It is recommended to use a solvent or gun oil together with a soft cloth and/or brush. Otherwise, the drop safety catch spring could be disengaged.
7. Clean firing pin assembly and bushing using a soft brush.
8. The gas piston may be cleaned as prescribed before.
9. When using a solvent, make sure that all traces of solvent are removed.
10. Oil the pistol parts lightly after cleaning including bore and gas cylinder. Excessive oil should be wiped off.

NOTE: CHECK DROP SAFETY CATCH AND SPRING VISUALLY FOR CORRECT ENGAGEMENT.

11. Install grips on receiver and tighten with grip screws.

NOTE: GRIPS HAVE TO SNAP POSITIVELY INTO THE RECEIVER.

12. Assemble pistol including firing pin assembly and bushing.

NOTE: DO NOT USE SOLVENTS OR GUN OILS WHICH CONTAIN CHLORINE OR ACIDS FOR CLEANING OF THE PISTOL.

13. Manually function test the pistol.

SECTION 7

SPECIFICATIONS

	P7M8	P7M13	P7M10	PSP
Caliber	9mm x 19	9mm x 19	9mm x 19	9mm x 19
Operating Principle	Recoil Operated	Recoil Operated	Recoil Operated	Recoil Operated
Action	Retarded Inertia bolt	Retarded Inertia bolt	Retarded Inertia bolt	Retarded Inertia bolt
Sights	Fixed	Fixed	Fixed	Fixed
Magazine Capacity	8-rounds	13-rounds	10-rounds	8-rounds
Weight without Magazine	1.75 lb (.80kg)	1.87 lb (.85kg)	2.69 lb (1.22kg)	1.73 lb (.785kg)
Weight with Magazine	2.10 lb (.96kg)	2.50 lb (1.13kg)	3.39 lb (1.54kg)	2.22 lb (.95kg)
Overall Length	6.73 in (171mm)	6.90 in (171mm)	6.90 in (171mm)	6.54 in (166mm)
Barrel Length	4.13 in (105mm)	4.13 in (105mm)	4.13 in (105mm)	4.13 in (105mm)
Sight Radius	5.83 in (148mm)	5.83 in (148mm)	5.83 in (148mm)	5.83 in (148mm)
Height of Pistol	5.04 in (129mm)	5.30 in (135mm)	5.83 in (145mm)	5.00 in (127mm)
Width of Pistol	1.14 in (29mm)	1.30 in (33mm)	1.30 in (33mm)	1.14 in (29mm)

ASSEMBLIES

1. Slide
2. Receiver
3. Magazine

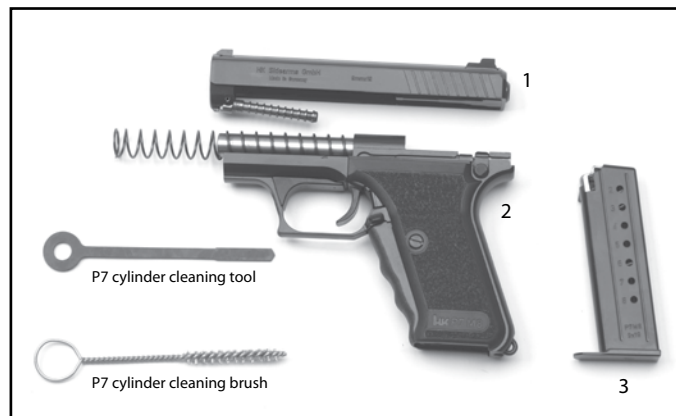

PARTS LIST - PSP PISTOL

Part No.	Designation	Part No.	Designation
1	Slide	24	Sear control lever
2	Front sight (height 5.7)	25	Catch
2.1	Front sight (height 5.9)	26	Ejector lever, complete
2.2	Front sight (height 6.1)	27	Spring
2.3	Front sight (height 6.3)	28	Elbow spring
2.4	Front sight (height 6.5)	29	Locking pin
2.5	Front sight (height 6.7)	30	Clamping sleeve
2.6	Front sight (height 6.9)	31	Slide retaining catch
3	Drop safety catch	32	Compression spring
4	Elbow spring	33	Cylinder head screw
5	Extractor	34	Recoil spring
6	Pressure pin	35	Receiver with barrel
7	Compression Spring	36	Squeeze cocker
8	Rear sight	37	Drag lever
9	Ring	38	Rocker
10	Cylindrical pin	39	Clamping sleeve
11	Compression spring	40	Cocking lever stop
12	Compression spring	41	Cocking latch
13	Firing pin	42	Compression spring
14	Bush	43	Elbow spring
15	Clamping sleeve	44	Grip shell, left
16	Fixing pin	45	Grip shell, right
17	Compression spring	46	Magazine catch
18	Clamping pin	47	Magazine housing
19	Piston	48	Follower
20	Elbow spring	49	Follower spring
21	Trigger	50	Locking plate
22	Cylindrical pin	51	Floorplate
23	Sear		

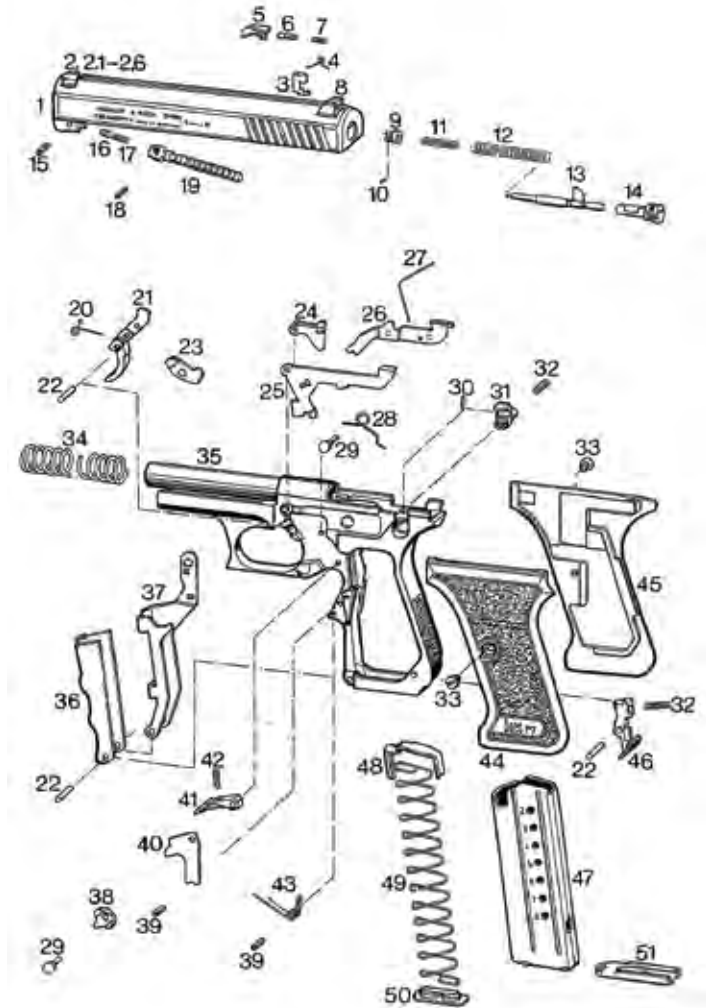

PARTS LIST - P7M8 PISTOL

Part No.	Designation	Part No.	Designation
1	Slide	28	Sear spring
2	Front sight (height 6.4)	29	Rocker spring
2.	Front sight (height 6.6)	30	Rocker spring axle
2.2	Front sight (height 6.8)	31	2 x Front sight/slide retainer pin
2.3	Front sight (height 7.0)	32	Slide removal button
2.4	Front sight (height 7.2)	33	Slide removal button spring
2.5	Front sight (height 7.4)	34	2 x Grip screw
2.6	Front sight (height 7.6)	35	Recoil spring
3	Drop safety catch	36	Receiver with barrel
4	Drop safety catch spring	37	Trigger heat shield
5	Extractor	38	Cocking lever
6	Extractor plunger	39	Drag lever
7	Extractor spring	40	Cocking lever axle
8	Rear sight	41	Rocker
9	Rear sight screw	42	Magazine catch axle
10	Firing pin collar	43	2 x Roll pin
11	Firing pin collar pin	44	Stop
12	Firing pin return spring	45	Cocking latch
13	Firing pin spring	46	Cocking latch spring
14	Firing pin	47	Cocking lever spring
15	Firing pin bushing	48	Grip-shell left
16	Piston roll pin	49	Grip-shell right
17	Piston plunger	50	Magazine catch
18	Piston plunger spring	51	Magazine catch spring
19	Plunger retaining roll pin	52	Magazine housing
20	Piston	53	Follower
21	Trigger spring	54	Follower spring
22	Trigger	55	Magazine locking plate
23	Trigger pin	56	Magazine floorplate
24	Transmission lever		
25	Disconnecter		
26	Slide stop		
27	Sear lever		

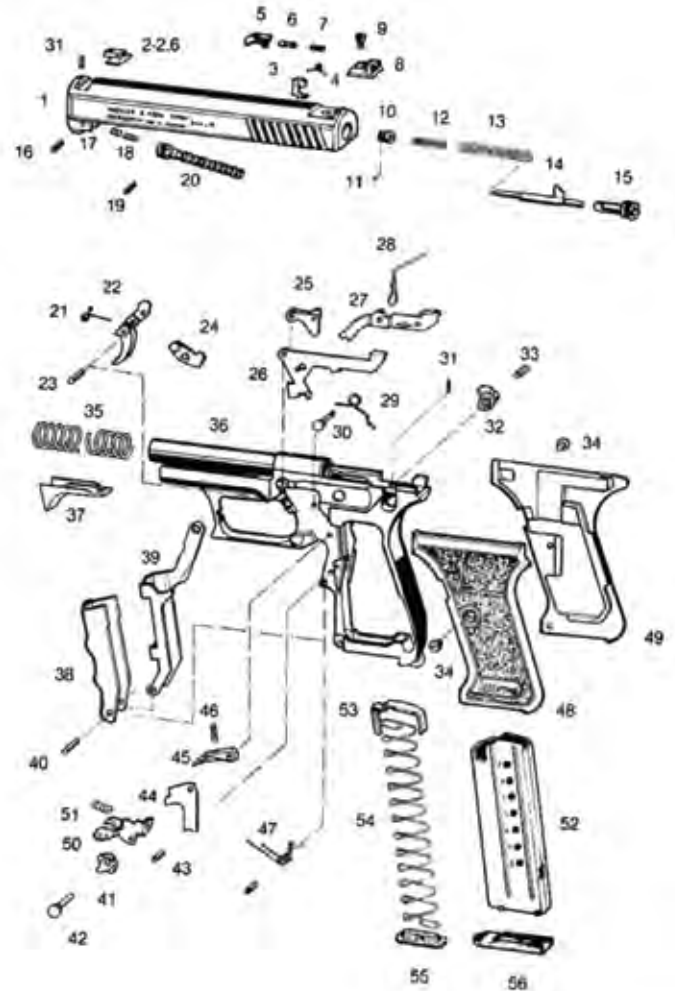

PARTS LIST - P7M13 & P7M10* PISTOLS

Part No.	Designation	Part No.	Designation
1	Slide	28	Sear spring
2	Front sight (height 6.4)	29	Rocker spring
2.1	Front sight (height 6.6)	30	Rocker spring axle
2.2	Front sight (height 6.8)	31	2 x Front sight/slide retainer pin
2.3	Front sight (height 7.0)	32	Slide removal button
2.4	Front sight (height 7.2)	33	Slide removal button spring
2.5	Front sight (height 7.4)	34	2 x Grip screw
2.6	Front sight (height 7.6)	35	Recoil spring
3	Drop safety catch	36	Receiver with barrel
4	Drop safety catch spring	37	Trigger heat shield
5	Extractor	38	Cocking lever
6	Extractor plunger	39	Drag lever
7	Extractor spring	40	Cocking lever axle
8	Rear sight	41	Rocker
9	Rear sight screw	42	Magazine catch axle
10	Firing pin collar	43	2 x Roll pin
11	Firing pin collar pin	44	Stop
12	Firing pin return spring	45	Cocking latch
13	Firing pin spring	46	Cocking latch spring
14	Firing pin	47	Cocking lever spring
15	Firing pin bushing	48	Grip-shell left
16	Piston roll pin	49	Grip-shell right
17	Piston plunger	50	Magazine catch
18	Piston plunger spring	51	Magazine catch spring
19	Plunger retaining roll pin	52	Magazine housing
20	Piston	53	Follower
21	Trigger spring	54	Follower insert
22	Trigger	55	Follower spring
23	Trigger pin	56	Locking plate
24	Transmission lever	57	Magazine floorplate
25	Disconnecter		
26	Slide Stop		
27	Sear lever		

* Diagram depicts P7M13. Except for slide dimensions, the P7M10 appears similar.

