

HK

In a world of compromise, some don't.

P7 Pistol  
Cal. 9 mm x 19

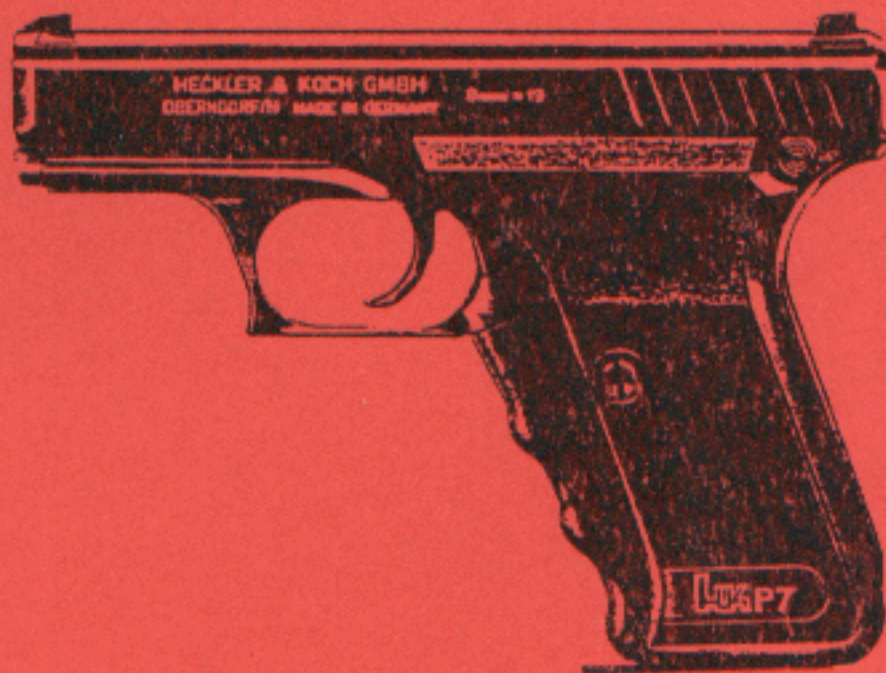

Instructions for Maintenance and  
Repair



<b>Contents</b>	<b>Page</b>
<b>1 Rules for carrying out of repair works</b> .....	<b>4</b>
1.1 General .....	4
1.2 Maintenance .....	4
1.3 Special aspects for handling pistols .....	4
<b>2. Service description</b> .....	<b>4</b>
2.1 General .....	4
2.2 Ordinary cleaning .....	5
2.2.1 Slide .....	5
2.2.2 Receiver with barrel .....	5
2.2.3 Magazine .....	6
2.3 Principal cleaning .....	6
2.3.1 Slide .....	6
2.3.2 Receiver with barrel .....	6
2.3.3 Stripping and assembling the magazine .....	6
<b>3. Inspections</b> .....	<b>7</b>
3.1 Slide, compl. ....	7
3.2 Receiver with barrel .....	7
3.3 Magazine .....	7
3.4 Testing the function of the pistol .....	8
3.4.1 Testing the operation of the disconnecter and the drop safety catch .....	8
3.4.2 Checking the functions .....	9
3.4.3 Cocking and trigger squeeze operation .....	9
3.4.4 Inspection of the safety and of the firing pin front and rear protrusions .....	10
3.5 Trouble-shooting chart .....	11
<b>4. Stripping and assembling the pistol</b> .....	<b>12</b>
4.1 General .....	12
4.2 Stripping the pistol .....	12
4.2.1 Slide .....	12
4.2.2 Drop safety catch .....	13
4.2.3 Extractor/Note a, b, c .....	13/14
4.2.4 Receiver .....	14
4.3 Assemble the pistol .....	15
4.3.1 Slide .....	15
4.3.2 Receiver .....	15/17
<b>5. Assembly groups</b> .....	<b>19</b>
5.1 Components .....	20/21
5.2 Maintenance control equipment .....	22
5.3 Special tools .....	23

## **1. Rules for carrying out of repair works**

### **1.1 General**

The P7 pistol is a semi automatic selfloading pistol in the calibre 9 mm x 19 Parabellum.

Weapons in need of repair are found out during weapons inquiries and arms inspections and during technical and practical service.

Defective weapons will be repaired on the spot by the competent armoury staff.

### **1.2 Maintenance**

In the case of faulty operation and bad shooting performance the weapon first of all has to be inspected to detect the causes of the deficiencies.

The maintenance staff must be adequately qualified in the field of weapons.

The following items must be clear:

1. Construction and operations of the weapon.
2. Function, working conditions and wear and tear of the components.
3. Utilization of gauges and control tools.
4. Correct and methodical carrying out of a weapon inspection.

Replace parts should only be mounted if after elimination of all other deficiencies the expected condition of the weapon cannot be achieved by other means as for example by cleaning the weapon.

### **1.3 Special aspects for handling pistols**

Keep pistols and magazines always lightly lubricated.

According to the frequency of utilization the magazine has to be cleaned, emptied and refilled; thereby keep an eye on battered or distorted magazines.

Damaged magazines are to hand over to the maintenance. Damaged and corroded cartridges shall be selected and withdrawn when cleaning. After loading the magazine, press the first round several times downward and let it move upward again. Note that the rounds do not jam in the magazine, that they are properly elevated and that they fit tightly to the magazine lips.

## **2. Service description**

### **2.1 General**

This gunner is responsible for the cleaning, care and the condition of the pistol. Defects and malfunctions are to report immediately to the competent armoury staff.

A cleaning has to be carried out as:

#### **Ordinary cleaning**

- In regular intervals when the weapon was not in use.
- After each use, where no principal cleaning is required.

#### **Principal cleaning**

- After each firing where a large number of rounds have been fired (about 1.000 rounds).
- When the pistol is soaked or badly fouled.
- In the case of malfunctions.

When the cleaning is finished and the weapon is assembled, always check the pistol for proper condition, easy functioning and troublefree operation.

#### **Cleaning agents**

For cleaning and care of the pistol please employ:

- Cleaning kit
- Brush (supplied for piston bushing)
- Cleaning rag
- Petroleum
- Gun oil or grease, free of chlorine and acid
- If applicable a chip of wood

**Do not clean the pistol with:**

- Metallic objects
- Synthetic materials as e.g. Nylon or Perlon when the weapon is hot of firing
- Chemical solvents as e.g. dry-cleaning spirit
- Cold or hot water

**Cleaning kit:** Drawing No. 100 200, Ident No. 211 023

- 1 Storage container
- 2 Oiler
- 3 Cleaning brush
- 4 Oil brush
- 5 Cleaning brush
- 6 Pull-through chain
- 7 Cleaning wick

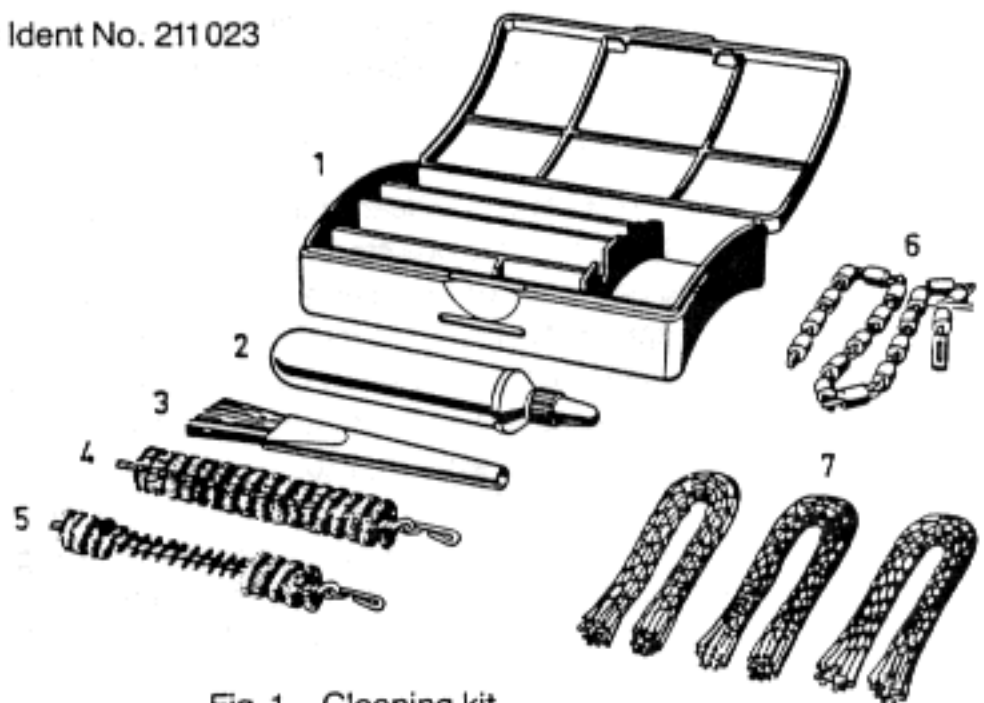

Fig. 1 Cleaning kit

**Brush compl.:** Drawing No. 9224-70, Ident No. 222 269

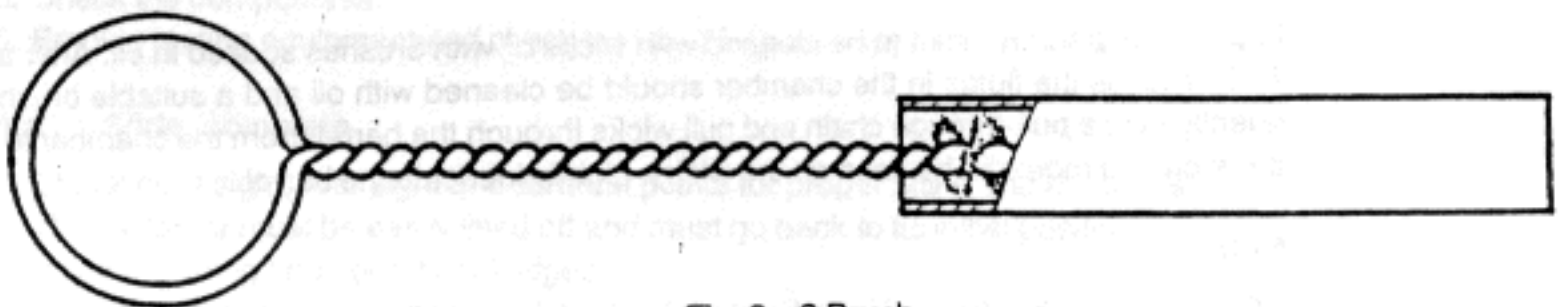

Fig. 2 8 Brush

**2.2 Ordinary cleaning**

This cleaning has to be carried out after each use of the pistol. The pistol must be disassembled as far as it is necessary to clean the fouled parts.

The cleaned parts have to be lubricated with a clean cloth.

**2.2.1 Slide**

Clean it with a cleaning brush or a cloth, mop the piston with a cloth and lubricate it lightly.

**2.2.2 Receiver with barrel**

Clean the receiver with a cleaning brush or a cloth. Pull through the barrel with the pull-through chain, oil brush and wicks from the chamber to the muzzle (first time if possible immediately after firing the pistol when the barrel is still warm to touch).

### 2.2.3 Magazine

Remove dirt and impurities from magazine lips and follower. Lightly lubricate the parts.

## 2.3 Principal cleaning

The degree of fouling of the pistol can depend from the number of fired rounds and the compound of the propellant. Therefore we recommend to carry out a principal cleaning of the pistol in regular intervals. From our experience this has to be done after about 1.000 rounds or one time a year.

### 2.3.1 Slide

Rinse the pistol in petroleum, clean it well, clean off, wipe it off with a dry cloth and lightly lubricate it. Do not use any hard objects for cleaning the slide.

Please pay attention to not disengaging, damaging respectively distorting or wrong mounting drop safety catch spring (4) of drop safety catch (3) which consequently would not function anymore.

When cleaning the drop safety catch with a brush, have an eye upon loose bristles which could cause the drop safety catch to get stuck when they are left there.

The part near the slide of piston (19) is cleaned with petroleum, mopped with a cloth and subsequently lightly lubricated. Please note that the sharp edges in the front section of the piston could be damaged by hard tools. Powder residues between the piston rings do not affect its operation, the piston is self-cleaning.

The firing pin system should be cleaned after about 1.000 rounds have been fired. Firing pin bushing (14) is rotated to the left and detached from firing pin (13). Subsequently both parts are carefully washed in petroleum, dried and lightly lubricated.

### 2.3.2 Receiver with barrel

We recommend to clean the piston bushing after a charge of about 1.000 rounds. The enclosed brush in pos. 8 is used for cleaning this cylinder by screwing the brush up and down the inside walls. By continuing this rotary movement the brush can be taken out.

### Cleaning the barrel

In principle the barrel has to be cleaned with wicks or with brushes soaked in oil. After a charge of about 1.000 rounds the flutes in the chamber should be cleaned with oil and a suitable brush (brass). Subsequently take a pull-through chain and pull wicks through the barrel, from the chamber to the muzzle, until there can no more dirt be seen on the wicks. Lightly lubricate the barrel.

### Note:

When the pistol has been cleaned and oiled after firing, this cleaning procedure has to be repeated on the ensuing day.

The moving parts of the trigger mechanism should be properly washed, dried and lightly oiled.

### 2.3.3 Stripping and assembling the magazine

Depress locking plate (50) by pushing a drift punch through the hole in the magazine floor plate (51), pull magazine floor plate forward and detach. During this operation the thumb of the other hand is held over the magazine floor plate, thus preventing the locking plate (50) and the follower spring (49) from catapulting out of the magazine. Take out parts.



Fig. 3 Stripping the magazine

In the case of bad fouling wash all parts in petroleum and remove dirt from magazine lips and the interior of the magazine. Lightly lubricate all metallic parts.

The assembly is carried out vice versa. Insert follower (48) and follower spring (49) in the magazine housing (47). Place locking plate (50) on follower spring and press it into the magazine housing. Push magazine floor plate (51) on magazine until the plug of the locking plate (50) engages in the hole of the magazine floor plate (51).

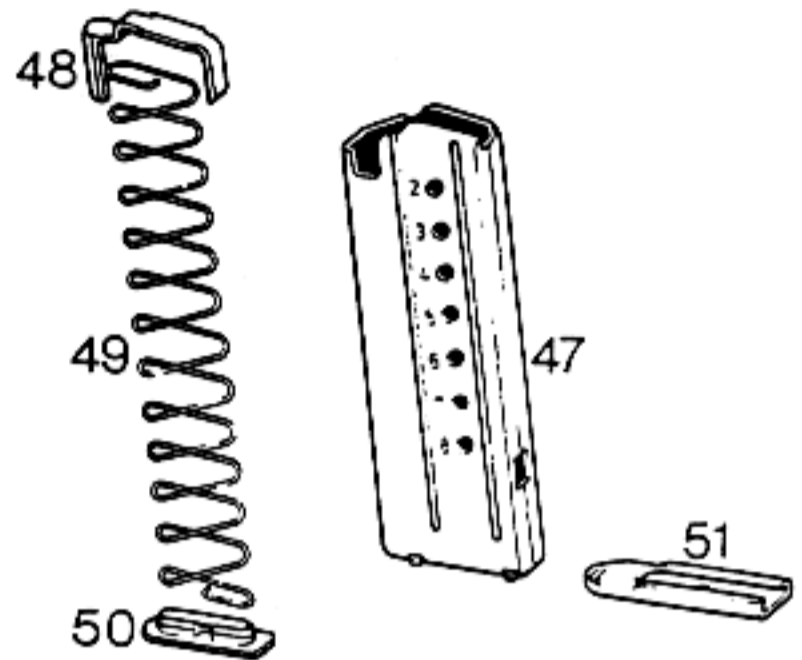

Fig. 4 Magazine

### 3. Inspections

Before and after each principal cleaning or repair the following items have to be checked:

1. Check the function of the assembled pistol.
2. Check function and condition of the magazine.
3. Inspect the service condition of the pistol.
4. Inspect assembly groups regarding to residues, damages and function.
5. Check the components.
6. Employ testing equipment and check for L2–L5 (pos. 1–4) maintenance.

#### 3.1 Slide, complete

- Check front sight, rear sight and contrast points for proper fitting and damages.
- The extractor must be easily lifted off and must go back to its initial position.
- Inspect guiding and operational edges.
- Inspect the first two reaction piston rings for fouling and damage. The piston detent (16) must spring back in the piston.
- Inspect the point of the firing pin for damage and the gripping surface for wear and tear. Compression springs (11) and (12) must not be entangled or twisted.
- Check firing pin bushing (14) for easy going and damage.
- Check drop safety catch (3) with drop safety catch spring (4) for wear and tear or damage. See 4.2.2 and note b (page 14).

#### 3.2 Receiver with barrel

- Make sure that the flutes in the chamber and the cartridge feeding ramp are clean.
- Check the inside walls of the barrel (e.g. for corrosion). After cleaning gauge L5 (pos. 4) is used to control the barrel diameter 8.8, beginning at the chamber.

#### 3.3 Magazine

- It must be possible to load 8 rounds into the magazine. Furthermore there must remain a free space at the bottom of about half a cartridge.
- The follower must be easily movable.

### 3.4 Testing the function of the pistol

- The slide must easily attachable to the grip and be properly manoeuvrable. Simultaneously the operation of the piston in the gas cylinder must be assured.
- Squeeze cocker (36) must properly disengage slide catch lever (25) and the force of the recoil spring (34) must completely close the slide when snapping forward. Release the squeeze cocker. It must glide smoothly over the drag lever (37) and disengage cocking latch (41).
- The slide retainer must be depressable all the way and release the slide.
- Cocking latch (41) with cocking latch spring (42) and receiver with barrel (35) must be correctly assembled.
- When the slide is in its forward position and the magazine is taken out, the slide catch lever (25) must automatically swivel downwards.

#### 3.4.1 Testing the operation of the disconnecter and the drop safety catch

##### Test procedure

Use distance gauge 9224 L2 for checking the disconnecter function (see page 22 item 1).

##### Performance

- Insert the inspection gauge for disconnecter function into the barrel, make sure that the clamping lever on the gauge is released and depress the pistol onto the gauge until the muzzle touches the space plate.
- Keep the pistol depressed, tighten the clamping lever and remove the space plate.

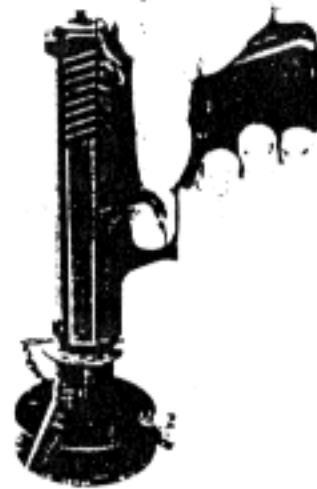

Fig. 5 Depressing the pistol onto the gauge

- Subsequently pull back the squeeze cocker (36) and depress the weapon again onto the gauge.
- When the trigger (21) is pulled now the firing pin (13) must not snap forward. If the firing pin snaps forward the pistol must be brought to the maintenance.

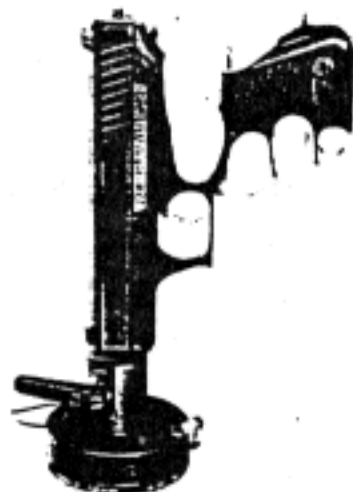

Fig. 6 Pulling the trigger



### 3.4.2 Checking the functions

- Load the magazine to its full capacity with 8 dummy rounds and insert it in the receiver.  
The magazine must be troublefree inserted in the grip and must be firmly retained by the magazine catch.
- Pull back the slide all the way for several times and let it snap forward again.  
When doing so all cartridges must be troublefree fed, extracted and ejected.
- After ejecting the last dummy round the slide catch lever has to catch and retain the slide in its rear position.
- Actuate the magazine catch.  
When disengaging the magazine catch the magazine must snap easily out of the receiver and must be removable without effort.
- Press back the squeeze cocker.  
The slide must snap forward now to its foremost position.
- Pull back slide all the way and press in the slide retainer.  
The slide must now be detachable from the receiver to the top. When the slide is mounted on the receiver again the slide must be firmly held by the slide retainer.

### 3.4.3 Cocking and trigger squeeze operation

- Press squeeze cocker back;  
the drag lever and the sear bar must push back the firing pin all the way and hold it in its ready to fire position.
- Loosen the grip;  
the cocking latch engages in the drag lever. The force required to hold the weapon in the cocked condition can be considerably reduced for there is a free space of about 3–4 mm between squeeze cocker and drag lever.
- Release the squeeze cocker all the way;  
the firing pin must return to its uncocked position.
- Depress the squeeze cocker thus cocking the firing pin and pull the trigger;  
the firing pin must snap forward.
- Keep the trigger pulled and press the squeeze cocker;  
when actuating the squeeze cocker the firing pin must be cocked and snaps forward.
- The trigger pull for the cocked firing pin shall be more than 17 N, but shall not exceed 24 N.

The trigger weight can be determined by means of the trigger pull gauge L4 (pos. 3).



### 3.4.4 Inspection of the safety and of the firing pin front and rear protrusions

#### Inspection gauges

Distance gauge 9224 L3 (see item 2, page 22) for firing pin front and rear protrusions.

#### Performance

##### Firing pin rear protrusion

- Unscrew and detach the right grip (45).
- Swivel sear bar (26) against the pressure of sear spring (27) until it touches the trigger.
- Place the weapon in this condition with the firing pin on the inspection gauge L3 and press it down until the firing pin abuts against the drop safety catch (3). Hold the weapon in a vertical position.
- Introduce depth gauge L3 into the barrel and push it down all the way.
- The centrally located movable measuring peg must now be sunk or even with the lower surface on the end of depth gauge L3.

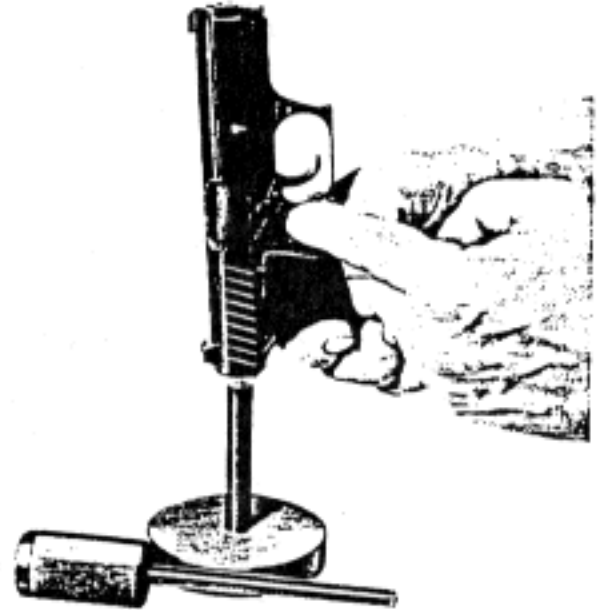

Fig. 7 Swivel sear bar

##### Firing pin front protrusion

- Pull back squeeze cocker to its rear stop and hold it in this position. Pull and release the trigger. The drop safety catch (3) must have released the firing pin to the front.
- Place the weapon with the firing pin on the inspection gauge L3 and press it down.
- Introduce depth gauge L3 into the barrel and push it down.

The centrally located movable measuring peg of depth gauge L3 must be positioned between the upper and the lower measuring levels of the gauge.

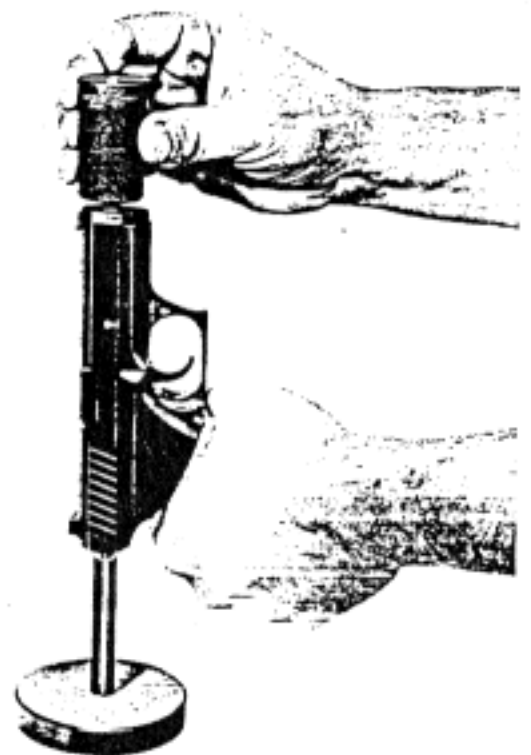

Fig. 8 Introduce depth gauge

### 3.5 Trouble-shooting chart

In the event of malfunctions the pistol must always be treated as if it is loaded until proved empty. The following list does not include all potential failures. Other causes than those indicated below are possible.

Trouble	Cause	Remedy
1) Cartridge is not detonated	<ul style="list-style-type: none"> <li>a) Ammunition failure (misfire)</li> <li>b) Drop safety catch spring (4) disengaged</li> <li>c) Firing pin bushing (14) or firing pin (13) broken.</li> </ul>	<p>Keep the pistol pointing down the range, ease off your grip and squeeze again (to recock the firing pin). Fire again. If the round still fails, feed a new one. Engage drop safety catch spring (4), check function.</p> <p>Fit new parts.</p>
2) Slide fails to open after the round has been fired	Cartridge jams in the chamber, due to distorted case or fouled chamber	Unload, pulling back slide so that the cartridge is ejected; clean the weapon if fouled.
3) Case is not ejected	<ul style="list-style-type: none"> <li>a) Insufficient slide recoil</li> <li>b) Extractor (5), extractor spring (7) or ejector (25) damaged</li> </ul>	<p>Unload the pistol, pull back slide, remove the case. Check freedom of movement, if fouled clean the weapon.</p> <p>Fit new parts.</p>
4) Failure to feed	<ul style="list-style-type: none"> <li>a) Chamber or flutes are fouled</li> <li>b) Cartridge distorted</li> <li>c) Recoil spring (34) weak or damaged</li> <li>d) Weak follower spring (49)</li> <li>e) Magazine or magazine lips damaged</li> </ul>	<p>Unload! Clean the weapon!</p> <p>Exchange cartridge</p> <p>Exchange recoil spring (34)</p> <p>Exchange follower spring (49)</p> <p>Exchange magazine</p>
5) Slide fails to stay open when the last round has been fired	<ul style="list-style-type: none"> <li>a) Weak follower spring (49)</li> <li>b) Slide catch lever (25) or rocker spring (28) damaged</li> <li>c) Follower (48) jams</li> </ul>	<p>Exchange follower spring (49)</p> <p>Fit new parts</p> <p>Clean follower (48) and magazine</p>
6) Open slide does not snap forward when squeeze cocker is depressed.	Rocker spring (28) unhinged or damaged	Check operation; engage or exchange spring (28)
7) Firing pin cannot be cocked	<ul style="list-style-type: none"> <li>a) Drop safety catch spring (4) disengaged or damaged</li> <li>b) Drag lever (37) or sear bar (26) twisted</li> <li>c) Sear spring (27) disengaged</li> <li>d) Firing pin (13) or firing pin bushing (14) damaged</li> <li>e) Firing pin collar (9) jams</li> </ul>	<p>Engage spring (4), or if damaged replace it</p> <p>Fit new parts</p> <p>Engage spring (27)</p> <p>Fit new parts</p> <p>Fit new parts</p>
8) Firing pin cannot be snapped	<ul style="list-style-type: none"> <li>a) Trigger (21), trigger spring (20) or transmission lever (23) broken</li> <li>b) Drag lever (37), sear bar (26) or disconnecter (24) damaged</li> </ul>	<p>Fit new parts</p> <p>Fit new parts</p>
9) Point of impact has changed	Rear or front sight misaligned	New sight adjustment

## 4. Stripping and assembling the pistol

### 4.1 General

For cleaning the pistol has to be disassembled. If several pistols are cleaned at the same time and at the same place, pay attention to not interchanging parts.

**Before stripping the weapon make sure that the magazine is empty and the chamber is clear.**

The pistol is stripped and assembled by employing special tools (see 5.3, page 23).

### 4.2 Stripping the pistol

Take out magazine by pressing magazine catch (46) to the front and removing the magazine with the same hand downwards out of the grip.

#### 4.2.1 Slide

Removal and installation of the firing pin.

Remove firing pin (13) with firing pin bushing (14). For this purpose depress squeeze cocker (36) until the firing pin (13) is even with the rear of the slide (1).

Press firing pin bushing (14) approx. 0.5 mm forward with special screwdriver (pos. 7) and rotate 90° to the right.

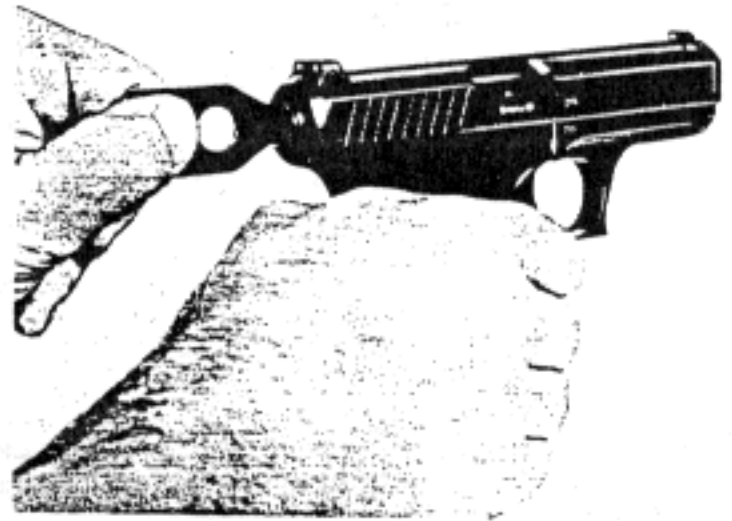

Fig. 9 Press firing bushing forward

Depress squeeze cocker (36) all the way and remove firing pin (13) with firing pin bushing (14).

#### Stripping for cleaning

Pull back slide all the way and make sure that there is no round in the chamber.

Let slide snap forward again.

Press slide retainer (31) on receiver.



Fig. 10 Remove slide



Pull back slide to its rear stop, lift it off, let it slowly slide forward and detach.



Fig. 11 Lift slide off

#### 4.2.2 Drop safety catch (3)

Carefully unhinge drop safety catch spring (4) by taking spring mounting tool pos. 1 and cautiously pressing the cropped shank to the bottom and unhinging, respectively disengaging it aside.

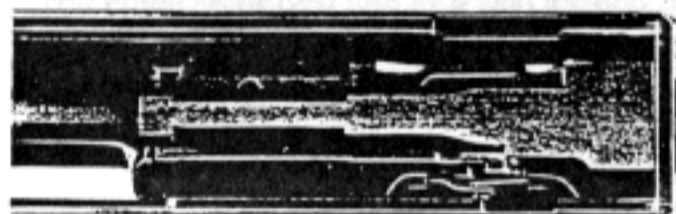

Fig. 12 Safety catch with spring

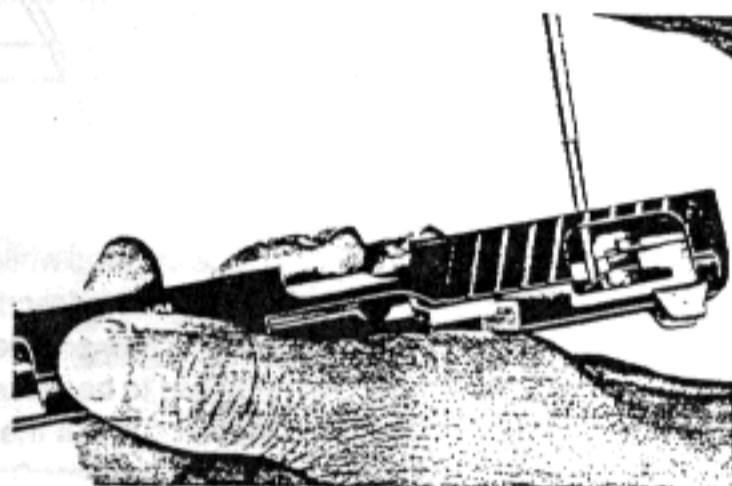

Fig. 13 Unhinge drop safety catch spring

#### 4.2.3 Extractor (5)

Insert spring pin pos. 2 in the groove of the extractor (5), and push extractor spring guide (6) to the rear. Then drift out the extractor from the bottom with a punch that is squeezed through the auxiliary hole in the slide. Remove extractor spring guide (6) and extractor spring (7) by light tapping them out of the slide.



Fig. 14 Inserting of spring pin

**Note:**

- a) When the slide (1) has to be burnished anew the synthetic bolts of the front sight (2) and rear sight (8) must be removed for cleaning boreholes  $\varnothing 19$  mm. Subsequently the synthetic bolts have to be replaced by new ones.

Drawing No. 9224-22.03

Ident No. 221900

These synthetic bolts are secured with a silicone adhesive e.g. type Delomet 2301 and flushingly inserted in the direction of the arrow.

- b) When the drop safety catch spring (4) of the drop safety catch (3) must be renewed one must pay heed to mounting spring (4) as shown in the illustration. By light compressing the shanks between thumb and forefinger the spring (4) can be lifted over the bolt and detached.

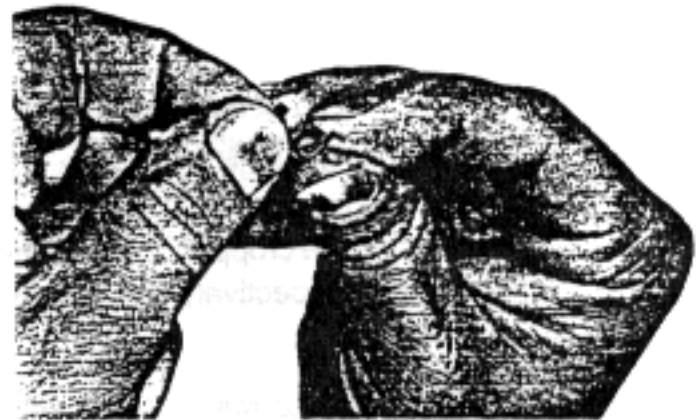
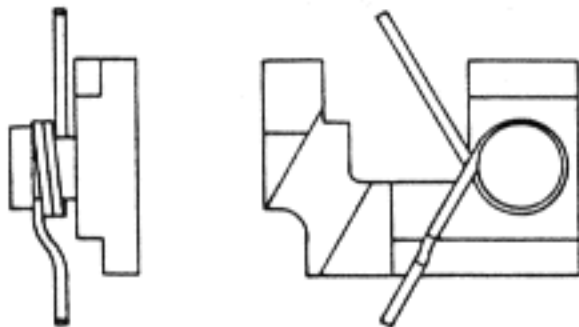
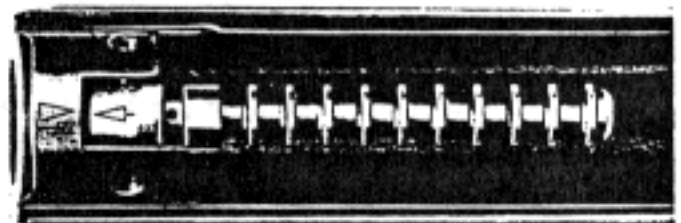

Fig. 15 Mounting drop safety catch spring

- c) The piston (19) is cleaned while being attached to the slide according to description 2.3.1. Only in the case of damage or extensive wear and tear the piston has to be disassembled, e.g. if failures to feed occur or if the recoil becomes too hard.

Pin punch pos. 4 is used for disassembling piston (19); for mounting the piston assembly pin pos. 6 has to be utilized.



The arrow on the piston must be visible on the top when the piston is mounted in the slide (1).

Fig. 16 Piston mounted

#### 4.2.4 Receiver

- Remove recoil spring (34) from the barrel.
- Unscrew grip screws (33), raise grip left (44) and right (45) at the front by means of the screwdriver, push them forward and detach.
- Disengage sear spring (27), drift cylindrical pin (22) out of the squeeze cocker (36) with pin punch pos. 4.
- Remove squeeze cocker (36), drag lever (37) and sear bar (26).
- Press cylindrical pin (22) out of trigger (21) and remove trigger with transmission lever (23) and trigger spring (20).
- Detach disconnecter (24).
- Drift out locking pin (29) to the top and take off slide catch lever (25) and rocker spring (28).
- Drift out locking pin for rocker (38) and remove rocker.
- Remove cocking latch (41) with cocking latch spring (42), detach stop (40).
- Drift cylindrical pin (22) out of the magazine catch (46) and take out magazine catch (46) with compression spring (32).
- Drive out slide retainer pin (30) to the bottom by means of drift punch pos. 5 and take out slide retainer (31) with compression spring (32) to the side.

For general cleaning it is sufficient to strip the weapon as described here.

## 4.3 Assemble the pistol

### 4.3.1 Slide

- Insert extractor spring (7) with extractor spring guide (6), press extractor (5) with your thumb against extractor spring (7) and to the bottom until it engages.
- Preassemble drop safety catch (3) with drop safety catch spring (4) (see instruction "b" page 14) and insert it in the slide. Adjust drop safety catch spring (4) in the proper position and mount it, utilizing the spring fitting kit pos.1. When the drop safety catch is lightly raised it must spring back to its initial position.
- Insert the complete firing pin (13) with the firing pin bushing (14) into the slide (1) until the end of the firing pin bushing (14) is approx. 0.5 mm inside the slide. Rotate firing pin bushing (14) with special screwdriver pos. 7 90° to the left until it engages and flushes with the rear end of the slide.

### 4.3.2 Receiver

- Press in all the way the lightly greased slide retainer (31) with its compression spring (32) and drive in slide retainer pin (30) from above until it flushes.
  - Insert lightly greased magazine catch (46) with compression spring (32) and fix them with assembling pin pos. 6, press in cylindrical pin (22).
  - The receiver is placed on its left side. Insert stop (40) and cocking latch (41) with greased cocking latch spring (42), place the other end of the cocking latch spring in the countersunk in the receiver. Fix the mounted parts with assembling pin pos. 6. Lay the receiver on its right side.
  - Stick on rocker (38) with its milled section pointing to the top and press out the assembling pin with locking pin (29). Check with spring fitting device pos. 3 whether the cocking latch spring (42) is properly positioned. Cocking latch (41) must be depressable all the way.
  - Mount slide catch lever (25).
  - Engage rocker spring (28) in the groove of the slide catch lever (25) and fix it with locking pin (29). Engage rocker spring (28) in the milled section of the rocker (38).
- 
- Lay the receiver on its left side and mount disconnector (24).



Fig. 17 Engaging rocker spring

- Preassemble trigger (21) with transmission lever (23), trigger spring (20) and cylindrical pin (22).



Fig. 18 Preassembling the trigger



- Mount preassembled trigger in the receiver.



Fig. 19 Mounting the trigger in the receiver

- Press in cylindrical pin (22), push it through the second bore in the trigger without using force, at the same time turn the receiver and align the bore for the cylindrical pin.

- Hold receiver with the left hand on its left side. Insert sear bar (26). Mount drag lever (37) from the bottom to the top against the pressure of the long shank of squeeze cocker spring (43). The borehole of drag lever (37) thereby engages in the plug of sear bar (26). Press cocking latch (41) all the way to the top and drag lever (37) and sear bar (26) further to the top into the guide groove for drag lever (37). Let drag lever (37) click into cocking latch (41).



Fig. 20 Mounting the drag lever

- Press squeeze cocker (36) in the same manner from the bottom to the top against the pressure of the short shank of squeeze cocker spring (43) until the cocking latch (41) disengages. Align the boreholes of squeeze cocker and drag lever and fix them with assembling pin pos. 6. Press in cylindrical pin (22).



Fig. 21 Mounting the squeeze cocker

- Engage sear spring (27).
- Check for proper functioning.
- Push grip left (44) and grip right (45) from the front into the mounting supports and secure them with the grip screws (33).
- Slide recoil spring (34) on the barrel.
- Mount slide on receiver and insert magazine.

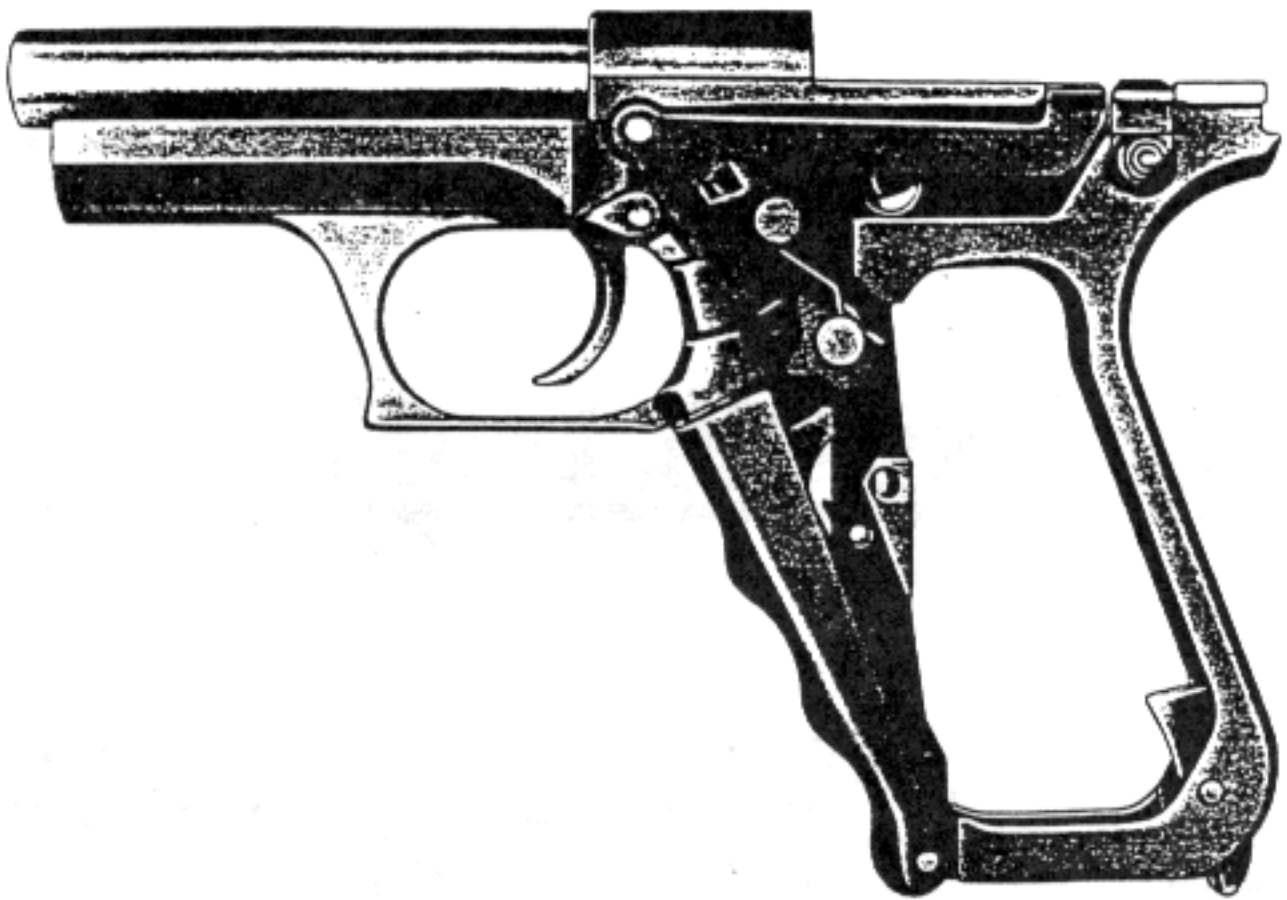

Fig. 22 Receiver assembled, left side view

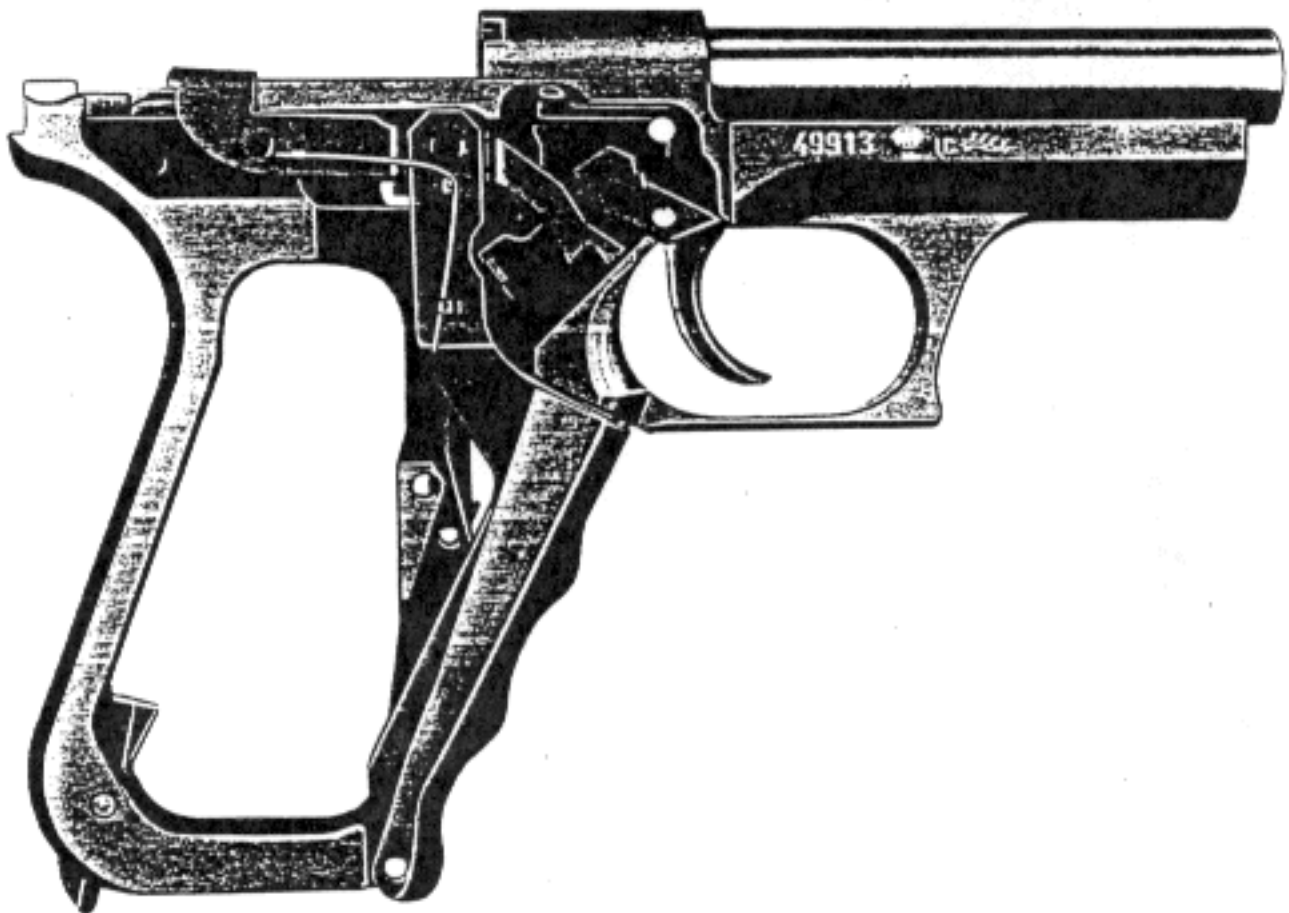

Fig. 23 Receiver assembled, right side view

## 5. Assembly groups

The P7 pistol consists of the following assembly groups:

- 1 Slide
- 2 Receiver
- 3 Magazine



Fig. 24 Assembly groups



## 5.1 P7 Selfloading Pistol – Components

Item	Part designation	Part No.	Ident No.
1	Slide	9224-21	221 881
2	Front sight (height 5.7 mm)	9224-22(09)	222 220
2.1	Front sight (height 5.9 mm)	9224-22(08)	222 221
2.2	Front sight (height 6.1 mm)	9224-22(01)	221 928
2.3	Front sight (height 6.3 mm)	9224-22(02)	221 929
2.4	Front sight (height 6.5 mm)	9224-22(03)	221 930
2.5	Front sight (height 6.7 mm)	9224-22(04)	221 931
2.6	Front sight (height 6.9 mm)	9224-22(05)	221 932
3	Drop safety catch	9224-28	221 874
4	Drop safety catch spring	9224-20.06	221 899
5	Extractor	9224-20.09	221 888
6	Extractor spring guide	9224-20.08	221 892
7	Extractor spring	9224-20.07	221 896
8	Rear sight	9224-24	221 893
9	Firing pin collar	9224-26.07	221 889
10	Firing pin collar pin	9224-26.09	221 908
11	Inertia spring	9224-26.05	221 898
12	Firing pin spring	9224-26.03	221 897
13	Firing pin	9224-26.01	221 882
14	Firing pin bushing	9224-20.05	221 883
15	Piston pin	3 x 12 DIN 7344	928 333
16	Piston detent	9225-30.03	222 478
17	Piston detent spring	9224-20.03	221 895
18	Piston retaining pin	1 x 6 DIN 7343	928 668
19	Piston	9225-30.01	222 479
20	Trigger spring	9224-11.08	221 877
21	Trigger	9224-11.07	221 854
22	Cylindrical pin	9224-11.04	221 880
23	Transmission lever	9224-11.05	222 282
24	Disconnecter	9224-11.06	221 857
25	Slide catch lever	9224-11.21	221 860
26	Sear bar	9224-18	221 916
27	Sear spring	9224-11.18	221 876
28	Rocker spring	9224-11.20	221 873
29	Locking pin (2 x)	9224-11.13	221 890
30	Slide retainer pin	1.5 x 8 DIN 1481	971 919
31	Slide retainer	9224-11.01	221 858
32	Compression spring (2 x)	9224-11.02	221 871
33	Grip screw (2 x)	M 4 x 5 Ko DIN 85	929 480
34	Recoil spring	9224-11.26	221 870
35	Receiver with barrel	9224-14	221 925
36	Squeeze cocker	9224-11.17	221 862
37	Drag lever	9224-11.16	221 856
38	Rocker	9224-11.12	221 864
39	Clamping sleeve (2 x)	3 x 10 DIN 1481	922 606
40	Stop	9224-11.09	222 186
41	Cocking latch	9224-11.10	221 863
42	Cocking latch spring	9224-11.11	221 872
43	Squeeze cocker spring	9224-11.15	221 875
44	Grip, left	9224-17	222 468
45	Grip, right	9224-19	222 467
46	Magazine catch	9224-11.28	222 465
47	Magazine housing	9224-50.01	221 902
48	Follower	9224-50.03	221 904
49	Follower spring	9224-50.05	221 905
50	Locking plate	9224-50.07	221 869
51	Magazin floor plate	9224-50.09	221 903



5.2 Maintenance control equipment for P7 selfloading pistol

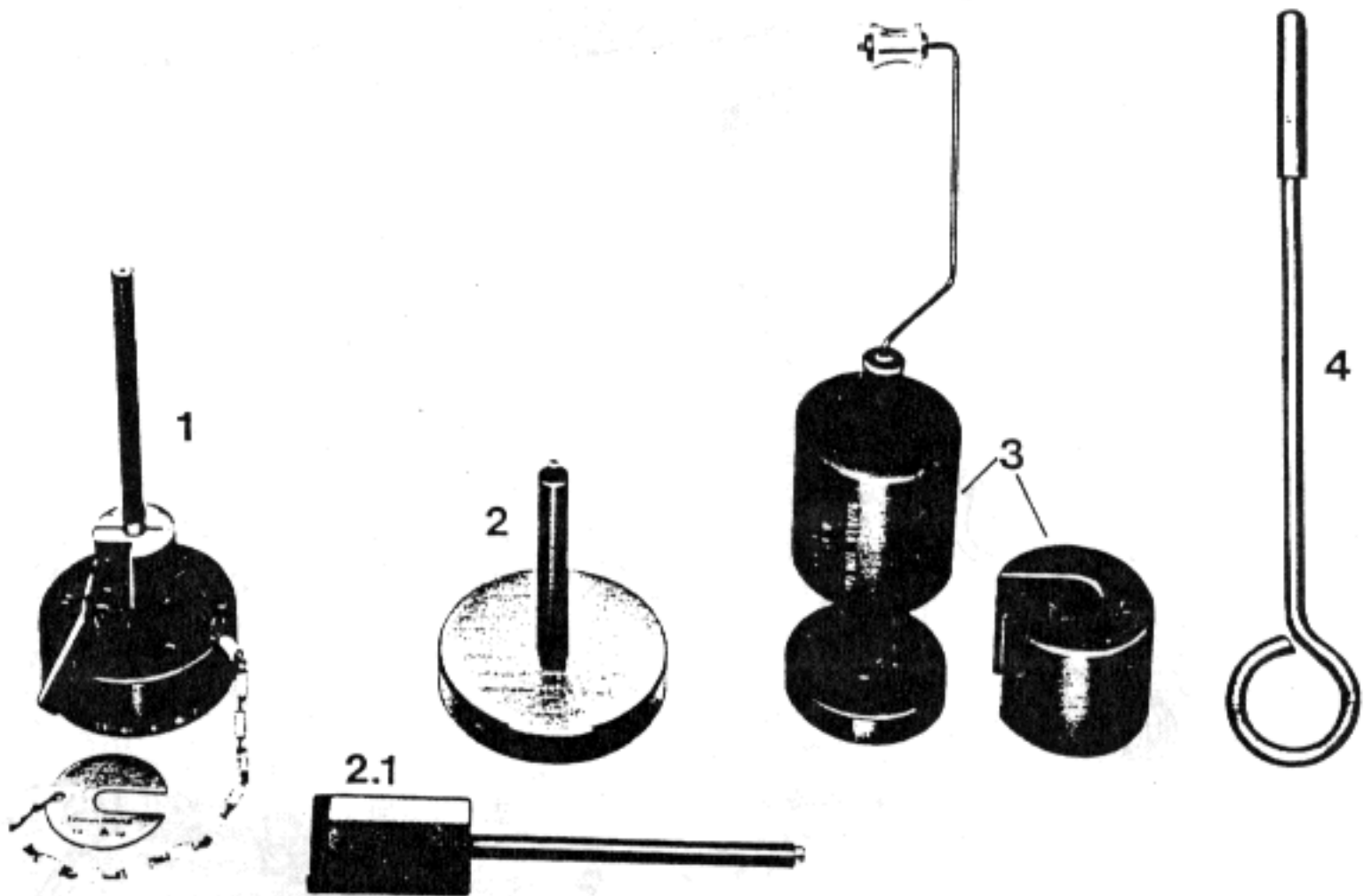

Pos.	Designation	Drawing No.	Ident No.
1	Control gauge for disconnecter function	9224 L2	323 779
2	Control gauge for firing pin protrusion	9224 L3	323 772
2.1	Depth gauge for firing pin front protrusion		
3	Control gauge for trigger pull	9224 L4	323 782
4	Barrel calibration gauge	9224 L5	324 242

### 5.3 Special tools for P7 selfloading pistol

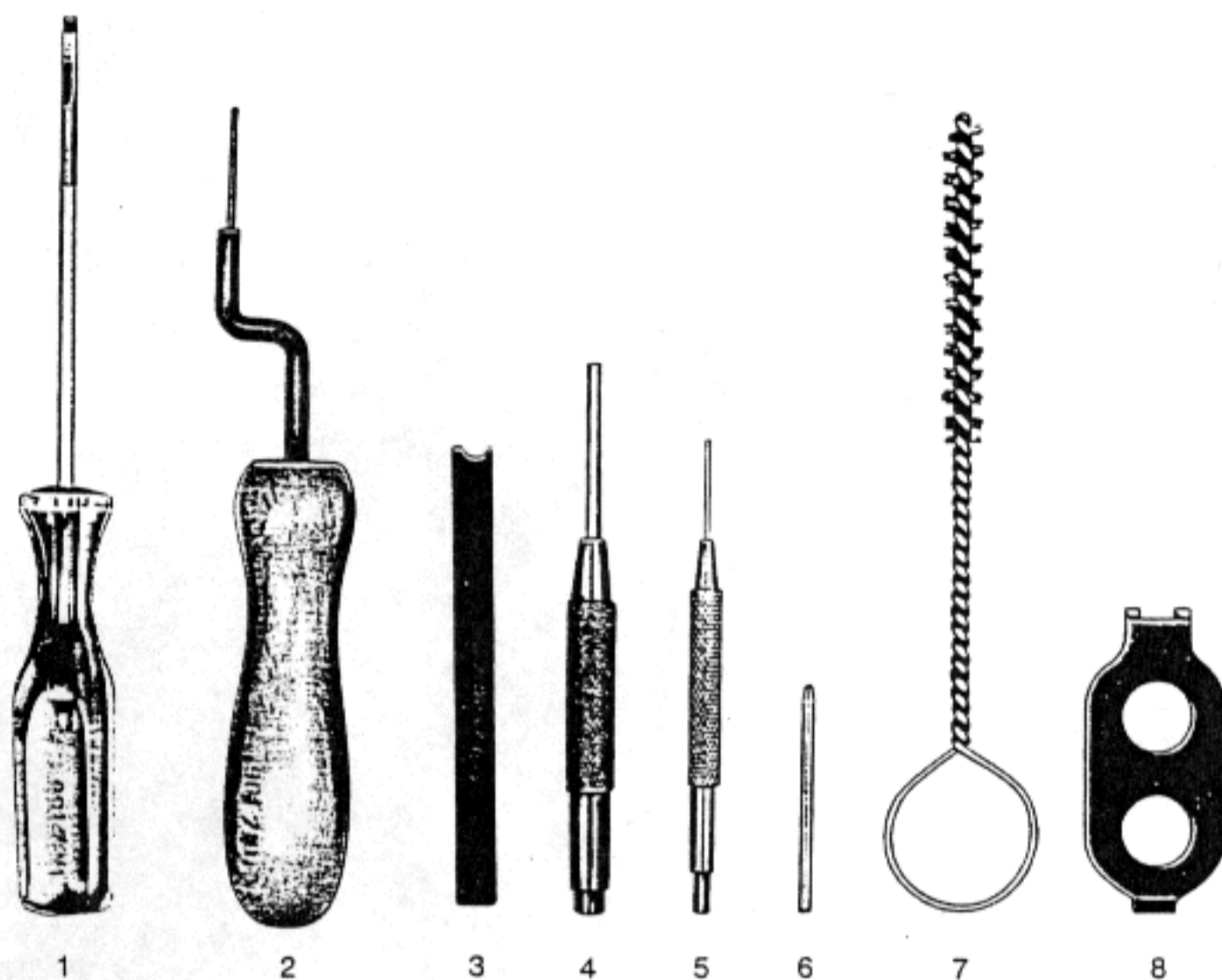

Pos.	Designation	Drawing No.	Ident No.
1	Spring fitting device	961 708	323 817
2	Spring eyebolt	961 710	323 830
3	Spring fitting device	961 707	323 816
4	Drift punch $\varnothing$ 2.9		954 525
5	Drift punch $\varnothing$ 1.4		957 309
6	Assembling pin	961 709	323 818
7	Brush	9224-70	222 269
8	Special screwdriver	9224-00.01	221 920