



**THOMPSON/CENTER**  
A Smith & Wesson® Company

## Safety & Instruction Manual

---

# T/C® Northwest Explorer™ Muzzleloading Rifle



**WARNING: Black Powder or an approved Black Powder substitute such as Pyrodex® are the only propellant powders that are safe to use in a muzzleloading firearm.**



**Read the instructions and warnings in this manual CAREFULLY BEFORE using this firearm.**

**THOMPSON/CENTER ARMS COMPANY, INC.**  
400 North Main Street  
Rochester, NH 03867  
TEL. 1-603-330-5659  
[www.tcarms.com](http://www.tcarms.com)



# **WARNING**



**READ THESE  
INSTRUCTIONS AND  
WARNINGS CAREFULLY.  
BE SURE YOU UNDERSTAND THESE  
INSTRUCTIONS AND WARNINGS  
BEFORE USING THIS FIREARM.  
FAILURE TO READ THESE INSTRUCTIONS  
AND TO FOLLOW THESE WARNINGS  
MAY RESULT IN SERIOUS INJURY  
OR DEATH TO YOU AND OTHERS  
AND DAMAGE TO PROPERTY**

**This SAFETY & INSTRUCTION  
MANUAL should always accompany  
this firearm and be transferred with it  
upon change of ownership or when the  
firearm is presented to another person.**

**Always keep your firearm pointed in a  
safe direction. Never point a firearm at  
anything you do not intend to shoot.**

**If you don't have a manual, printed  
copies are available free upon request  
by contacting the factory at the address  
below. They are also available via  
download from the company's web site  
shown below.**

**THOMPSON/CENTER ARMS CO., INC.  
• CUSTOMER SUPPORT •  
400 NORTH MAIN STREET  
ROCHESTER, NH 03867  
TEL.: 1-603-330-5659  
[www.tcarms.com](http://www.tcarms.com)**

YOUR SAFETY RESPONSIBILITIES .....	3
SAFE STORAGE & TRANSPORTATION .....	8
SAFETY RULES FOR THE T/C NORTHWEST EXPLORER .....	10
BASIC EQUIPMENT FOR SHOOTING T/C NORTHWEST EXPLORER ..	13
UNDERSTANDING BLACK POWDER .....	14
UNDERSTANDING PYRODEX® .....	15
T/C NORTHWEST EXPLORER TRIGGER & HAMMER .....	16
PREPARATION FOR FIRING .....	17
SERIAL NUMBER & MODEL IDENTIFICATION .....	18
INSPECTING THE TC NORTHWEST EXPLORER .....	19
CHARGING THE T/C NORTHWEST EXPLORER .....	20
PATCHING THE ROUND BALL .....	25
PRIMING THE T/C NORTHWEST EXPLORER .....	28
FIRING THE T/C NORTHWEST EXPLORER .....	30
UNLOADING AND UNCHARGING .....	32
FIELD CLEANING .....	34
THOROUGH CLEANING .....	36
DISASSEMBLY OF THE T/C NORTHWEST EXPLORER .....	39
SIGHT ADJUSTMENT .....	41
LIMITED LIFETIME WARRANTY .....	42
CONTACT & SHIPPING FOR SERVICE .....	43
LOAD COMPONENTS .....	45
SUGGESTED LOADS FOR THE T/C NORTHWEST EXPLORER .....	46
PATCHED .490" ROUND BALL LOADS .....	47
LUBRICATED T/C MAXI-BULLET LOADS .....	47

# ***YOUR SAFETY RESPONSIBILITIES***

## **SAFETY IS YOUR NUMBER ONE RESPONSIBILITY!!!!**

At home, in the field, at the range, or anywhere, the first concern of every firearm owner should be safety. Apply the following safety rules in every situation, with any kind of firearm. If you feel uncertain about any operational aspects of your firearm, please contact Thompson/Center before proceeding with its operation.



**WARNING: YOU MUST FOLLOW ALL OF THESE SAFETY RULES TO ENSURE THE SAFE USE OF YOUR FIREARM. THE FAILURE TO FOLLOW THE INSTRUCTIONS AND WARNINGS IN THIS MANUAL COULD CAUSE SERIOUS PERSONAL INJURY OR DEATH TO YOU OR OTHERS AND DAMAGE TO PROPERTY.**

As a firearm owner, you accept a demanding responsibility. How serious you take this responsibility can be the difference between life and death. There is no excuse for careless or abusive handling of your firearm. At all times handle your firearm with intense respect for its power and potential danger.

---

## ***YOUR SAFETY RESPONSIBILITIES CONT'D***

---

- **ALWAYS KEEP YOUR FIREARM POINTED IN A SAFE DIRECTION.** Never point a firearm at anyone or anything you do not intend to shoot whether or not it is loaded. This is particularly important when loading, unloading, or field stripping the gun. ALWAYS control the direction of the firearm.
- **ALWAYS TREAT EVERY FIREARM AS IF IT IS LOADED AND WILL FIRE.** Do not take anyone's word that the firearm is uncharged or unprimed – always check for yourself. Never pass your firearm to another person until the action is open and/or on safe you visually check that it is uncharged and unprimed. Keep your muzzleloading firearm uncharged and unprimed and safely stored when not in use.
- **NEVER PLACE YOUR FINGER INSIDE THE TRIGGER GUARD OR ON THE TRIGGER UNLESS YOU INTEND TO FIRE.** Ensure that other objects do not touch the trigger.
- **ALWAYS BE SURE OF YOUR TARGET AND WHAT IS BEYOND IT.** Always be sure of where the bullet will strike and shoot only where there is a safe back stop free of obstructions, water or other surfaces which can cause ricochets. Be sure your bullet will stop behind your target. Bullets can glance off many surfaces like rocks or the surface of water and travel in unpredictable directions with considerable velocity. Do not fire randomly into the sky.
- **NEVER CROSS OBSTACLES SUCH AS FENCES OR STREAMS WITH A CHARGED OR PRIMED MUZZLELOADING FIREARM.** Always make certain your muzzleloading firearm is unprimed before crossing a fence, climbing a tree, jumping a ditch or negotiating other obstacles.
- **SAFE FIREARM HANDLING IS YOUR PERSONAL RESPONSIBILITY AT ALL TIMES.** Firearms are dangerous and can cause serious injury or death if they are misused or used inappropriately. Safety must be the prime consideration of any one who owns or handles firearms. Accidents are the result of violating the rules of safe firearm handling and common sense. Firearm safety training is available. Contact your firearms dealer, law enforcement agency, local sportsman's club, etc. for availability.
- **YOU ARE RESPONSIBLE FOR THE FIREARM AT ALL TIMES.** In owning a firearm, you must undertake full-time responsibility for your firearm's safety and security. You must protect yourself and all others against injury or death from misuse of the firearm 24 hours a day.
- **FIREARM SECURITY IS YOUR RESPONSIBILITY.** You must secure firearms safely from children and/or unauthorized users. Your firearm should always be kept unloaded and locked when not in use. Never assume that the use of this lock is sufficient to safely secure your firearm. You must always evaluate your personal situation and employ the security systems that meet your needs and prevent children and unauthorized users from gaining access to your firearm.

---

## ***YOUR SAFETY RESPONSIBILITIES CONT'D***

---

- **APPROPRIATE USE FOR YOUR FIREARM MEANS USING YOUR FIREARM FOR LEGAL PURPOSES.** For example - target shooting, hunting and lawful resistance of deadly criminal force. It is your responsibility to ensure that you are in compliance with all applicable laws and ordinances regarding the use of your firearm.
- **NEVER RELY ON MECHANICAL FEATURES ALONE.** Only your safe firearm-handling habits will ensure the safe use of your firearm. This is your responsibility.
- **ALWAYS SAFELY STORE AND SECURE YOUR FIREARM.** Safe and secure storage of your firearm is one of your most important responsibilities. It is a full-time responsibility. You must always secure your firearm and ammunition and loading components separately so that they are not accessible to children and/or other unauthorized persons.
- **NEVER KEEP AMMUNITION AND LOADING COMPONENTS IN THE SAME LOCATION AS THE FIREARM.** Store each in a separate and secure place.
- **ALWAYS WEAR EYE PROTECTION THAT IS SPECIFIED FOR USE WITH FIREARMS** every time you handle your firearm for cleaning and maintenance.
- **ALWAYS WEAR EYE AND EAR PROTECTORS THAT ARE SPECIFIED FOR USE WITH FIREARMS** every time you discharge your firearm. Make sure others in the vicinity of where you will be shooting do so as well.
- **NEVER USE ALCOHOL OR DRUGS BEFORE OR WHILE SHOOTING.** Do not use your firearm if you are on any medication which impairs, even slightly, your mental or physical ability.
- **ALWAYS HAVE ADEQUATE VENTILATION.** Discharging firearms in poorly ventilated areas, cleaning firearms, or handling ammunition and loading components may result in exposure to lead and other substances known to cause birth defects, reproductive harm, and other serious physical injury. Review the warnings and labels for all ammunition and loading components and cleaning products carefully. Wash hands thoroughly after exposure.
- **BEFORE HANDLING ANY FIREARM, UNDERSTAND ITS OPERATION.** Not all firearms are the same. Familiarize yourself with the mechanical features of any firearm you intend to use. If you feel uncertain about any operational aspects of your firearm, please contact Thompson/Center before proceeding with its operation.
- **NEVER ALLOW A FIREARM TO BE USED BY INDIVIDUALS WHO DO NOT UNDERSTAND ITS SAFE OPERATION OR HAVE NOT READ THESE FIREARM SAFETY RULES.**

---

## ***YOUR SAFETY RESPONSIBILITIES CONT'D***

---

- **ALWAYS USE THE CORRECT COMBINATION OF LOAD COMPONENTS FOR YOUR PARTICULAR MUZZLELOADING FIREARM** as detailed in this manual.
- **BE CERTAIN THE BARREL IS CLEAR OF OBSTRUCTIONS BEFORE SHOOTING.** Mud, water, snow or other objects may inadvertently lodge in the barrel bore. A small obstruction can cause a dangerous increase in pressure and may damage your firearm and cause injury to yourself and others.
- **BE SURE ALL ACCESSORIES, SUCH AS HOLSTERS, GRIPS, SLINGS, SCOPES AND OTHER ACCESSORIES ARE COMPATIBLE** with the firearm and that the accessories do not interfere with safe operation. It is your responsibility to understand and follow all of the instructions in this manual, as well as those which may be supplied with your ammunition and loading components and any accessory.
- **NEVER DISASSEMBLE YOUR FIREARM** beyond the procedures outlined in this manual. Improper disassembly or re-assembly of your firearm may be dangerous and can lead to serious injury or death.
- **NEVER MANIPULATE, ADJUST OR CHANGE ANY OF THE INTERNAL COMPONENTS OF YOUR FIREARM UNLESS SPECIFICALLY INSTRUCTED TO DO SO IN THIS MANUAL.** Improper manipulation of any other internal component may affect the safety and reliability of your firearm and may cause serious injury or death.
- **NEVER ALLOW ANY ALTERATION OR REPLACEMENT OF PARTS IN YOUR THOMPSON/CENTER FIREARM UNLESS PERFORMED BY A QUALIFIED GUNSMITH** using genuine Thompson/Center parts. If you do otherwise, improper functioning of your firearm may occur and serious injury or death and damage to property may result.



**WARNING: SAFE USE OF A FIREARM IS YOUR PERSONAL RESPONSIBILITY AND THE FAILURE TO FOLLOW ALL OF THESE BASIC SAFETY RULES MAY RESULT IN SEVERE PERSONAL INJURY OR DEATH TO YOU OR OTHERS AND DAMAGE TO PROPERTY. YOU ARE THE MOST IMPORTANT SAFETY DEVICE WHEN IT COMES TO THE USE OF YOUR FIREARM AND THOMPSON/CENTER AND ITS PARENT COMPANY WILL NOT BE RESPONSIBLE FOR ANY PERSONAL INJURY, DEATH OR PROPERTY DAMAGE THAT RESULTS FROM: (1) THE CRIMINAL OR NEGLIGENT USE OF THIS FIREARM; (2) A DISREGARD OF THESE SAFETY INSTRUCTIONS AND WARNINGS; (3) IMPROPER OR CARELESS HANDLING OF THIS FIREARM; (4) THE USE OF NON-STANDARD, DEFECTIVE, IMPROPER LOAD COMPONENTS OR (5) IMPROPER OR NEGLIGENT MODIFICATIONS OR REPAIRS TO THE FIREARM.**

---

## ***YOUR SAFETY RESPONSIBILITIES CONT'D***

---

- **NEVER CLIMB TO OR DESCEND FROM A TREE STAND WITH A PRIMED MUZZLELOADING FIREARM. NEVER RAISE OR LOWER A PRIMED MUZZLELOADING FIREARM TO OR FROM A TREE STAND.** Failure to follow this rule may cause serious injury and/or death to the shooter or bystanders and damage to property.
- **NEVER LEAN A CHARGED AND PRIMED RIFLE AGAINST A TREE, A WALL OR ANY SURFACE WHERE IT MAY FALL OVER.** Once the rifle has been charged it is your responsibility to guard against situations that may result in an accidental discharge. Failure to follow this rule may cause serious injury and/or death to the shooter or bystanders and damage to property.
- **THE T/C NORTHWEST EXPLORER IS DESIGNED FOR USE WITH OPEN SIGHTS ONLY - NO PROVISION HAS BEEN MADE FOR MOUNTING A SCOPE.**



**WARNING: DO NOT DRILL HOLES IN THE BARREL AS THIS COULD WEAKEN THE BARREL STRUCTURE LEADING TO A RUPTURE. A RUPTURED BARREL CAN CAUSE SERIOUS INJURY AND/OR DEATH TO THE SHOOTER OR BYSTANDERS AND DAMAGE TO PROPERTY. DRILLING HOLES IN THE BARREL ALSO VOIDS ALL WARRANTIES.**

- **NEVER MODIFY ANY OF THE PARTS IN YOUR FIREARM.** Do not add or replace any of the parts in your firearm unless they are genuine Thompson/Center parts and you follow the instructions supplied by Thompson/Center. If you do otherwise, improper functioning may occur and serious injury or death may result. In addition to the dangers presented, the use of non-factory parts, including but not limited to, barrels and springs, voids all warranties.



**WARNING: NEVER RELY ON MECHANICAL SAFETY FEATURES OF THE FIREARM ALONE. ONLY YOUR SAFE FIREARM HANDLING WILL ENSURE THE SAFE USE OF YOUR FIREARM. THIS IS YOUR RESPONSIBILITY.**

---

# **SAFE STORAGE & TRANSPORTATION**

---



**WARNING: ALWAYS POINT THE MUZZLE IN A SAFE DIRECTION.**



**WARNING: FIREARMS ARE DANGEROUS WHEN USED AND STORED IMPROPERLY. THEY POSE A RISK OF SERIOUS OR FATAL INJURIES. FIREARMS CAN BE ESPECIALLY DANGEROUS TO CHILDREN WHEN THEY ARE STORED IN AN IRRESPONSIBLE AND UNSAFE MANNER. FOR YOUR SAFETY AND THE SAFETY OF OTHERS, IT IS IMPERATIVE THAT YOU KEEP YOUR FIREARM LOCKED AND UNLOADED IN A SECURE PLACE. THE AMMUNITION AND LOADING COMPONENTS SHOULD BE STORED IN A SEPARATE, SECURE LOCATION WHEN IT IS NOT IN USE. SAFE AND SECURE STORAGE OF YOUR FIREARM IS ONE OF THE MOST IMPORTANT RULES OF FIREARM SAFETY. YOUR FAILURE TO FOLLOW THESE RULES MAY RESULT IN SERIOUS INJURY OR DEATH TO YOU OR OTHERS.**

- **ALWAYS SECURE YOUR FIREARM IN A MANNER THAT WILL PREVENT UNAUTHORIZED ACCESS.** Whenever your firearm is not in use, keep it unloaded and locked. Your safety and the safety of others requires that you always secure and store your firearm in a manner that will prevent unauthorized access. Never leave a firearm unattended unless it is locked, unloaded and secured.



**WARNING: NEVER LOCK A LOADED FIREARM AND NEVER LOAD A LOCKED FIREARM!!**

- **ALWAYS STORE YOUR FIREARM AND AMMUNITION AND LOADING COMPONENTS SEPARATELY** so that they are not accessible to children or other unauthorized persons. Safe and secure storage of your firearm and ammunition and loading components are your responsibility. It is a full-time responsibility.
- **NEVER ASSUME THAT A “HIDING” PLACE IS A SECURE STORAGE METHOD.** Others may be aware of your storage location or come upon it by chance. It is your personal responsibility to use common sense when storing your firearm and ammunition and loading components and to always make sure they are not accessible to children or other unauthorized persons.
- **NEVER TRANSPORT A CHARGED OR PRIMED MUZZLE-LOADING FIREARM.** When transporting your firearm, be sure it is uncharged, unprimed and securely locked. Safe and secure transportation of your firearm is your responsibility.



---

## **SAFE STORAGE & TRANSPORTATION CONT'D**

---

- **ALWAYS FOLLOW THE LAW!** Many jurisdictions have laws that make it a crime to keep a firearm unlocked and in an area accessible to children or others. Keeping a firearm locked and unloaded when not in use is not only common sense safety practice... IT IS THE LAW. You must be familiar with all local, state, and federal laws regarding the safe storage and transportation of your firearm. Failure to know and follow the law may result in unauthorized access or use of your firearm by another. Obey all laws relating to the storage and transportation of firearms. Your local police department or gun shop can furnish you with available information on storing and/or transporting a firearm safely and legally.
- **YOUR FIREARM IS YOUR RESPONSIBILITY.** You must prevent your firearm from being stolen or from being used by untrained or unqualified individuals. Keep it locked, uncharged, unprimed and secured when not in use.

---

# ***SAFETY RULES FOR THE T/C NORTHWEST EXPLORER***

---

In addition to the general Firearm Safety Responsibilities covered so far in this manual, there are additional guidelines specific to black powder muzzleloading firearms that must be adhered to at all times to ensure the safety of the shooter and others.

- **NEVER USE SMOKELESS POWDER OF ANY TYPE OR IN ANY QUANTITY IN A MUZZLELOADING FIREARM, AND NEVER MIX POWDERS.** The use of any smokeless powder could result in a detonation or explosion which could cause injury and/or death to the shooter or bystanders and damage to property.
- **USE ONLY BLACK POWDER OR AN APPROVED BLACK POWDER SUBSTITUTE SUCH AS PYRODEX® TO LOAD YOUR MUZZLELOADING FIREARM.** Never use even small amounts of smokeless powder, even if it is black in color. The use of any other propellant may cause injury or death to the shooter or bystanders and damage to property.
- **NEVER SMOKE WHILE USING YOUR MUZZLELOADER.** The spark from a lighted cigarette, cigar or pipe can ignite Black Powder or a Black Powder substitute such as Pyrodex, and Percussion Caps or Primers. Smoking around a charged and/or primed muzzleloader, percussion caps, primers, priming powder or supply of powder may cause premature firing of the firearm or an explosion of the powder can, horn or flask causing serious injury and/or death to the shooter or bystanders and damage to property.
- **BEFORE LOADING, MAKE SURE THE MUZZLELOADING FIREARM IS NOT ALREADY CHARGED.** To make sure it is uncharged, keep the muzzle pointed in a safe direction and insert the ramrod provided with the rifle into the bore. Note the position of the ramrod in relation to the muzzle. It will be slightly below the end of the barrel if the rifle is not loaded.
- **NEVER EXCEED THE RECOMMENDED MAXIMUM CHARGE LISTED IN THIS BOOK.** To do so could result in injury or death to the shooter or bystanders.
- **WHEN LOADING, BE CERTAIN THAT THE PROJECTILE IS LOADED IN THE PROPER SEQUENCE AND THAT IT IS SEATED FIRMLY AGAINST THE POWDER CHARGE.** Serious personal injury or death can result if the projectile is not seated properly. To provide a reference mark for future loadings, mark the ramrod at the muzzle once a projectile has been loaded to the proper depth. NOTE: Be sure to recheck the ramrod mark if you change loading components or alter the ramrod.

---

## **MUZZLELOADER SAFETY RULES CONT'D**

---

- **NEVER POUND ON THE RAMROD.** Black Powder and approved Black Powder substitutes such as Pyrodex® are potentially sensitive to impact and could ignite from impact. Always keep the muzzle directed away from your face or body when loading.
- **BLACK POWDER AND BLACK POWDER SUBSTITUTES SUCH AS PYRODEX® LEAVE CORROSIVE RESIDUES IN THE BORE AND ON THE FIREARM.** A thorough cleaning is absolutely necessary before storage for any amount of time to keep the firearm functioning correctly and in safe condition.
- **UNDERSTAND THE TERMINOLOGY** “Charge” or “Charged” which applies to the presence of a propellant powder charge and projectile in the bore of the muzzleloading firearm.
- “Uncharge” or “Uncharged” refers to the opposite condition to “Charged” and indicates that the powder charge and projectile have been either fired or removed and that the bore is completely clear.  
  
“Prime” or “Primed” applies to the act of placing a primer, cap or priming powder in or on a muzzleloader.
- “Unprime” or “Unprimed” refers to the opposite condition of “Primed” and indicates that the primer, cap or priming powder has been removed from the firearm or is not in place.
- **NEVER PRIME YOUR MUZZLELOADING FIREARM UNTIL YOU ARE READY TO FIRE IT.** Your muzzleloader should remain unprimed until the instant before firing. After you prime the firearm, your full concentration should be on the target and the act of firing.
- **A SHARP OR HEAVY BLOW TO THE EXTERNAL HAMMER CAN FRACTURE PARTS AND CAUSE A MALFUNCTION OR DISCHARGE OF THE FIREARM.** An accidental discharge may cause serious injury and/or death to the shooter or bystanders and damage to property.
- **NEVER HAND A CHARGED MUZZLELOADING FIREARM TO ANOTHER PERSON.** Once charged, a muzzleloading firearm requires your complete attention. Never charge the firearm and then hand it to another shooter. Equally, you should never shoot a muzzleloading firearm that has been charged by someone else. Only the person doing the loading knows whether the firearm has been charged properly.

---

## **MUZZLELOADER SAFETY RULES CONT'D**

---

- **DO NOT CHARGE YOUR T/C NORTHWEST EXPLORER MUZZLELOADER DIRECTLY FROM A CAN, HORN OR FLASK.** A spark from a previous firing may ignite the stream of powder being poured into the firearm and cause the container to explode. The explosion of a powder can, horn or flask may cause serious injury and/or death to the shooter or bystanders and damage to property. Use a separate pre-calibrated measuring device containing small quantities of powder to charge your firearm. Keep the muzzle directed away from your face and body when loading.
- **ALWAYS KEEP SUPPLIES OF POWDER, PRIMERS AND CAPS WELL AWAY FROM A FIRING POSITION OR SHOOTING BENCH.** A powder horn, flask, can of powder, or quantity of primers or caps can ignite with deadly force if exposed to sparks or intense heat. Follow the manufacturer's instructions for safe handling and storage of powder and primers or caps. Keep unused powder and primers or caps well away from firearms that are being discharged. Sparks from the discharge of a muzzleloading firearm may cause an unused supply of powder or primers or caps to ignite causing serious injury and/or death to the shooter or bystanders and damage to property.
- You must follow this procedure every time a firearm leaves your hand, is cleaned, handed to you or another person, transported or stored.



**WARNING: NEVER RELY ON MECHANICAL FEATURES ALONE. ONLY YOUR SAFE FIREARM HANDLING WILL ENSURE THE SAFE USE OF YOUR FIREARM. THIS IS YOUR RESPONSIBILITY.**

---

# ***BASIC EQUIPMENT FOR SHOOTING THE T/C NORTHWEST EXPLORER***

---

In order to shoot your T/C Northwest Explorer muzzleloader, the accessories and equipment listed below will be necessary:



**WARNING: DO NOT ATTEMPT TO SHOOT YOUR MUZZLELOADING FIREARM UNTIL YOU HAVE READ THIS MANUAL IN ITS ENTIRETY AND UNDERSTAND IT FULLY. FAILURE TO READ AND FOLLOW THESE INSTRUCTIONS COULD RESULT INJURY AND/OR DEATH TO THE SHOOTER OR BYSTANDERS AND DAMAGE TO PROPERTY. IF YOU ARE UNABLE TO UNDERSTAND ANY OR ALL OF THIS MATERIAL, CALL THE CUSTOMER SERVICE DEPARTMENT AT THOMPSON/CENTER.**

1. Proper eye protection - specified for use with firearms.
2. Proper ear protection - specified for use with firearms.
3. Black Powder or an approved Black Powder substitute such as Pyrodex<sup>®</sup>, (in granular form - not pelletitized) in the appropriate type for your firearm.
4. A Powder Measure.
5. Projectiles: Appropriate for your firearm.
6. No.11 Percussion caps
7. Bore cleaning patches.
8. A Jag to hold cleaning patches.
9. An appropriate bore cleaning solvent (Like T/C's No.13<sup>™</sup>).
10. An appropriate oil or rust inhibiting lubricant (Like T/C's Natural Lube 1000 Plus Bore Butter<sup>™</sup>).

---

# UNDERSTANDING BLACK POWDER

---



Shooting muzzleloading firearms requires the shooter to be both a reloader and a rifleman at the same time. It requires strict adherence to the instructions set forth in this booklet. Failure to follow these instructions may cause damage to the firearm and injury and/or death to the shooter or bystanders and damage to property.

**NOTE:** Black Powder is manufactured in four specific types or granulations for use in firearms. Generally speaking, it is the granule size which determines the appropriate use of Black Powder. The largest granulations are naturally the slowest burning and, therefore, work best in large caliber rifles and shotguns. Pistols or smaller caliber rifles require a finer or faster burning powder. The priming powder used in the pan of a flint lock is extremely fine and fast burning for positive ignition of the main charge.

## **FG (commonly called Single “F”)**

The muzzleloading enthusiast finds little use for this very coarse black powder. It's use is restricted to the large bore (10, 8, 4 gauge) shotguns of yesteryear.

## **FFG (commonly called Double “F”)**

This is a very popular powder for .45 caliber to .58 caliber rifles. It is also used for 12, 16, and 20 gauge muzzleloading shotguns. While it is not considered a pistol powder, it is sometimes used in very large caliber single shot pistols. It is recommended for use in most T/C muzzleloaders.

## **FFFG (commonly called Triple “F”)**

Due to its wide range of uses, Triple “F” is the black powder that is most commonly found on a dealer's shelf. It is used in all percussion revolvers, most single shot pistols, and most of the smaller (under .45 caliber) rifles. In a pinch, it can also be used to prime a flint lock.

## **FFFFG (commonly called Four “F”)**

The finest of all currently available black powders, Four “F” is best used for priming flint locks. Due to its limited use, it is sometimes difficult to obtain.

When purchasing Black Powder be certain that it is in the original manufacturer's container and that its granulation or type is clearly marked on the label. Follow the storage and handling precautions which are on the label. If you have any questions concerning the safe handling or storage of Black Powder, write to the manufacturer of the powder. Additional information on powder storage is available from the National Fire Protection Association, P.O. Box 9146, Quincy, Mass. 02269. Or call 1-800-344-3555. Ask for pamphlet #495.

---

# UNDERSTANDING PYRODEX®

---



PyroDEX® is a propellant powder designed for use in muzzleloading cap lock rifles, pistols and shotguns. PyroDEX is not Black Powder. In accordance with the manufacturer's instructions, PyroDEX relates closely to Black Powder on a volume to volume basis (not weight of charge). In other words, a black powder measure that is set to dispense 70 grains of black powder will, in fact, dispense approximately 52 grains of PyroDEX (by weight). This lighter charge of PyroDEX will provide a charge which is ballistically similar to 70 grains of Black Powder. For all practical purposes, knowing the actual weight of a charge of PyroDEX may be informative, but not necessary. Your black powder measure will dictate the proper amount by its graduations according to volume. If you want to know the actual comparative weight of a PyroDEX charge, contact the manufacturer, Hodgdon Powder Co. Inc., 6231 Robinson, Shawnee Mission, KS 66202-1332.

PyroDEX® does not ignite as easily as Black Powder and, consequently, it is not recommended for use in flint lock firearms. Flint locks require strong, positive ignition and should be charged and primed with Black Powder of the appropriate granulation only.

## **PYRODEX® CTG - FOR BLACK POWDER CARTRIDGES.**

This powder was designed to be used in early model breech loading cartridge firearms (rifles, pistols & shotguns) which were intended for use with Black Powder only. It has no application in Thompson/Center muzzleloading firearms. It is listed here simply for identification purposes.

**PYRODEX® RS (or PYRODEX SELECT "RS") RIFLE & SHOTGUN POWDER.** Designed for use in all calibers of percussion muzzleloading rifles and shotguns, this powder has a wide application. It may be used with all Thompson/Center muzzleloading rifles and shotguns. PyroDEX Select (RS) may also be used in these applications.

**PYRODEX® P - PISTOL POWDER.** Designed for use in most percussion muzzleloading pistols and cap and ball revolvers, this powder has application in the Thompson/Center Patriot™ Pistol.

**PYRODEX® PELLETS** - These pre-formed charges are designed for use in most Thompson/Center muzzleloaders and are suitable where permitted by state and local laws. Use the appropriate caliber and charge weight pellet for your muzzleloading rifle.

The reader should bear in mind that Thompson/Center does not manufacture or sell powder of any type. If there is ever a question as to the proper application of a particular powder or the safety of a given charge, write to the manufacturer of the powder. Adhere to the safe handling and storage precautions printed on the manufacturer's container and never purchase or use powders which have been removed from their original container. **USE OF THE WRONG PROPELLANT** may cause injury and/or death to the shooter or bystanders and damage to property. For information on PyroDEX write to Hodgdon Powder Co., Inc., 6231 Robinson, Shawnee Mission, KS 66202-1332.

# T/C NORTHWEST EXPLORER TRIGGER & HAMMER



**WARNING: THE FAILURE TO FOLLOW THESE FIREARM SAFETY REQUIREMENTS WILL CAUSE SERIOUS PERSONAL INJURY OR DEATH TO YOU OR OTHERS.**

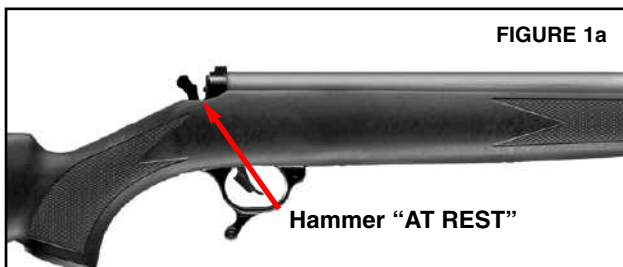

- **THE HAMMER SHOULD BE IN THE "AT REST" POSITION DURING LOADING AND WHEN CARRYING (Figure 1a).**

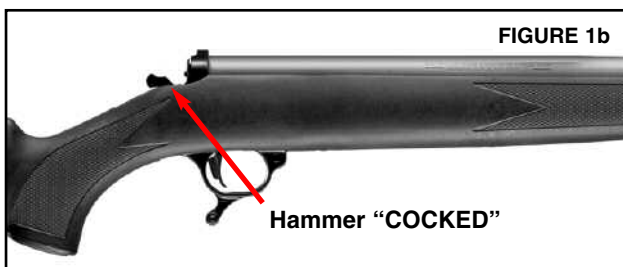

- **THE HAMMER SHOULD BE IN THE "COCKED" POSITION ONLY WHEN IN THE PROCESS OF FIRING (Figure 1b).**

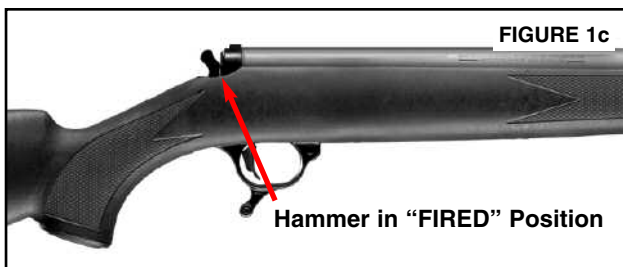

- **WHEN THE T/C NORTHWEST EXPLORER IS COCKED AND THE TRIGGER IS PULLED - THE HAMMER CONTACTS THE FIRING PIN (Figure 1c).**



---

# **PREPARATION FOR FIRING**

---



**WARNING: THE FAILURE TO FOLLOW THESE FIREARM SAFETY REQUIREMENTS WILL CAUSE SERIOUS PERSONAL INJURY OR DEATH TO YOU OR OTHERS.**

- **ALWAYS TREAT ALL FIREARMS AS IF THEY WERE LOADED.**
- **ALWAYS WEAR ADEQUATE AND PROPER EAR PROTECTORS SPECIFIED FOR FIREARM USE** to prevent permanent damage to your hearing. Make sure others who are nearby are wearing ear protection as well.
- **ALWAYS WEAR PROPER CLOTHING WHEN FIRING A MUZZLELOADER** wearing long sleeves is recommended to protect arms from debris that may be ejected during firing.
- **ALWAYS WEAR SAFETY GLASSES SPECIFIED FOR FIREARM USE**, whether indoors or out. Safety glasses should protect your eyes from the firing flash and particles associated with the discharge of a muzzleloader. Failure to do so creates a risk of personal injury from particle or debris spitting or ricochets. Make sure others who are nearby are wearing eye protection as well.
- **ALWAYS BE ALERT AND ALWAYS FOLLOW THE SAFETY INSTRUCTIONS OF THE RANGE OFFICER.** Never shoot if you are tired, cold or impaired in any way.
- **ALWAYS BE AWARE OF OTHER PEOPLE** so that persons cannot accidentally walk into the line of fire.
- **THE SHOOTER (AND ALL OTHERS IN THE SHOOTING AREA) MUST ALWAYS BE IN A POSITION THAT IS OUT OF THE LINE OF FIRE** and are not within an area where they may be struck by ricochets or particles ejected from a firearm.
- **NEVER SHOOT AT HARD SURFACES, WATER OR RANDOMLY INTO THE SKY.** Always select a place to shoot that has a safe backstop and is free from obstructions and water surfaces which cause ricochets.
- **NEVER USE ALCOHOL OR DRUGS BEFORE OR WHILE SHOOTING OR HANDLING ANY FIREARM.**
- **NEVER SMOKE WHILE SHOOTING OR HANDLING A MUZZLELOADING FIREARM.**
- **ALWAYS KEEP LOADING COMPONENTS AND LOADING RESERVES WELL AWAY FROM THE MUZZLELOADER WHEN FIRING.**

# **SERIAL NUMBER & MODEL I.D.**

FIGURE 2a



FIGURE 2b

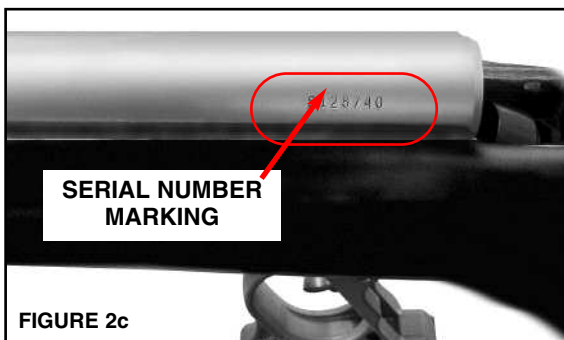

FIGURE 2d



# INSPECTING



**WARNING: ALWAYS POINT THE MUZZLE IN A SAFE DIRECTION.**



**WARNING: ANY TIME THAT YOU HANDLE AN T/C NORTHWEST EXPLORER, OPEN THE ACTION AND ENSURE THAT IT IS UNCHARGED AND UNPRIMED.**

## INSPECTING

- With your finger away from the trigger and with the hammer in the “AT REST” position (Figure 3), open the action to inspect by pushing forward on the trigger guard spur (Figures 3&4).

- Look into the breech plug to make sure there is no percussion cap present (FIG 5) and look through the breech plug channel to ensure that there is no charge in the bore.



- Verify that the bore is clear and free of obstructions.
- You must follow this procedure every time a firearm leaves your hand, is cleaned, handed to you or another person, transported or stored.

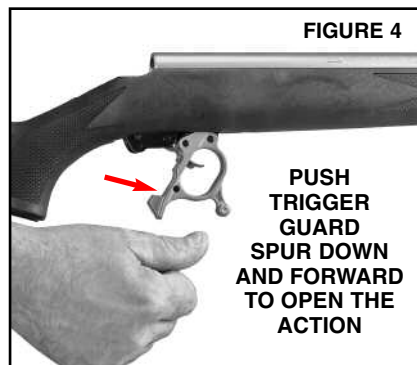

 **WARNING:  
NEVER RELY  
ON MECHANICAL  
FEATURES  
ALONE. ONLY YOUR  
SAFE GUN HANDLING  
WILL ENSURE THE  
SAFE USE OF YOUR  
FIREARM. THIS IS  
YOUR RESPONSIBILITY.**

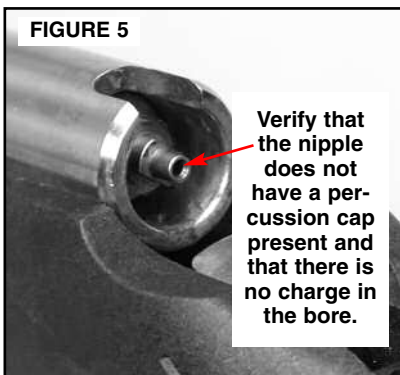

---

# **CHARGING THE T/C NORTHWEST EXPLORER MUZZLELOADER**

---



**WARNING: ALWAYS POINT THE MUZZLE IN A SAFE DIRECTION.**

NOTE: The loading data found in this manual was compiled using Black Powder or granular (loose) Pyrodex<sup>®</sup> RS Powder as a propellant (Not Pellets). With any other approved Black Powder substitute, follow the instructions supplied by the manufacturer and heed all warnings and instructions as they apply to loading and usage of that product.

- Inspect the bore for obstructions and oil or grease (and clean if necessary). This is true with the rifle as it comes from the factory, as it has been treated with anti-rust compound that needs to be cleared before use.
- Do not load the muzzleloading firearm until you have read and fully understand this manual.
- Do not load the muzzleloading firearm until you are ready to use it. Keep your finger off the trigger and outside the trigger guard until you are ready to fire.

Read this manual in its entirety before attempting to load your firearm. Improper loading and use of your firearm can cause injury and/or death to the shooter or bystanders and damage to property.

Study the photo on page 22 carefully and read all the captions before you charge your muzzleloading rifle. The photo shows a shooter in the process of loading a T/C Northwest Explorer muzzleloader.

To open the T/C Northwest Explorer - tip the trigger guard spur down and forward to unlock the action and allow the breech to pivot downward. Look into the breech and check to make sure there is no percussion cap present (See Figures 3 & 4 on page 19). Hold the muzzle up to the light and look through the ignition channel to ensure that there is no charge present. (See Figure 5 on page 19). To close the T/C Northwest Explorer, pull the trigger guard up and back while securely holding the forend with your other hand. Practice opening and closing the rifle before attempting to load and fire this firearm.

To make sure it is unloaded, keep the muzzle pointed in a safe direction and insert the ramrod provided with the rifle into the bore. Note the position of the ramrod in relation to the muzzle. It will be slightly below the end of the barrel if the rifle is not loaded. Commit this exercise to memory and practice it every time that you handle the T/C Northwest Explorer, or any other muzzleloader. Before you attempt to load it - before you store it away - before you hand it to a friend or leave it unattended, always check to ensure that the firearm is unprimed and uncharged.

---

## **CHARGING THE T/C NORTHWEST EXPLORER CONT'D**

---

Wipe the bore free of all oil before loading. Be meticulous with your cleaning - for the presence of any amount of oil in the barrel or chamber can dampen the powder charge and cause the rifle to misfire or hangfire (see section on "Cleaning"). Point the muzzle in a safe direction and snap several No.11 percussion caps on the nipple before charging. This will help ensure positive ignition and clear away any oil that may have accumulated in the ignition channel.

Adjust the powder measure to dispense the desired charge and fill it with Black Powder or an approved Black Powder substitute, such as Pyrodex. To achieve accuracy, consistency in the powder charge is required. Fill the measure exactly the same each time. Set the rifle on its butt and hold the muzzle away from your face and body as pictured on page 22. Pour the measured charge down the barrel and strike the side of the barrel several sharp raps with the heel of your hand. This will settle the powder into the chamber area of the barrel.

Do Not pound on the ramrod or beat the projectile with excessive force, so as to crush the powder and distort the bullet.

**NOTE:** Under normal conditions the T/C Northwest Explorer muzzleloader is unloaded simply by firing it into a suitable and safe backstop. There are, however, conditions under which the firearm cannot be fired and the charge must be removed manually:

- The projectile is not seated firmly against the powder charge, stop immediately! Do not attempt to fire the gun. You must remove the charge and then clean the barrel.
- The T/C Northwest Explorer muzzleloader is loaded in a proper manner yet fails to fire after repeated priming and clearing of the ignition fire channel.
- You are at a location that is unsuitable for discharging the firearm before transporting it.

Proceed to the section on ***Unloading and Uncharging*** in this manual if these conditions or any others occur where the muzzleloader cannot be discharged safely.

## CHARGING THE T/C NORTHWEST EXPLORER CONT'D

**WARNING: IMPROPERLY CHARGING YOUR T/C NORTHWEST EXPLORER MUZZLELOADER CAN BE DANGEROUS. STUDY THIS PHOTO CAREFULLY BEFORE PROCEEDING.**

**Barrel must be held securely with muzzle upwards - directed away from your face and body.**

**Only Use Black Powder or an approved Black Powder substitute, such as Pyrodex®. Use a T/C graduated powder measure and do not overcharge. NEVER charge directly from a powder flask, can or powder horn.**

**The T/C Northwest Explorer must be unprimed during charging.**

**Stay mentally alert. This task requires your complete attention.**

**Keep Eyes, ears & arms protected.**

**Do Not Smoke while loading any muzzleloader.**

**Always Keep components & reserve powder well away from the firearm.**

**Rifle's butt resting firmly on the ground & supported by the side of the shooter's foot to prevent slipping.**

FIGURE 6

---

## **CHARGING THE T/C NORTHWEST EXPLORER CONT'D**

---

### **Loading Lubricated Conical Lead Bullets When Using loose Black Powder or Granular Pyrodex®**

Care should be taken to seat the bullet firmly against the powder charge. Do not pound on it. Again, mark your ramrod at the muzzle, ensuring that each time you seat a bullet on the powder the projectile is seated to the same depth.

If you are loading an all-lead conical bullet like T/C's Maxi-Ball or Maxi-Hunter®, proceed as follows; do not use any kind of cloth patch with these projectiles. They should be lubricated prior to loading, and are designed to be shot as cast (not sized further). T/C Maxi-Balls and Maxi-Hunters come from the factory prelubricated. However, if you find some unlubricated bullets, we recommend that you lubricate these bullets with an all-natural lubricant, free of petroleum, like T/C Natural Lube 1000 Plus Bore Butter™. When loading a Maxi-Ball or Maxi-Hunter bullet into the muzzle, you will note how only the forward most bearing band grooves to the rifling when loading. The base of the bullet upsets (increases in diameter) upon firing, causing it to fill the grooves, thus stabilizing the projectile and aiding accuracy.

Hold the rifle as pictured on page 22 and pour your measured powder charge into the barrel. Start the lubricated bullet into the bore with your fingers. The base of the projectile will enter the bore easily with finger pressure. Drive the projectile down about four inches into the barrel with the long end of the bullet starter (Figure 7).

Using the ramrod, push the projectile the remainder of the way down the barrel until it contacts the powder charge. The conical bullet must be seated firmly against the powder charge. Seat the projectile with exactly the same pressure shot after shot to aid in accuracy.

Remove the ramrod from the bore and return it to the thimbles before you prime the firearm.



**Figure 8**

Push the projectile down the barrel with the ramrod and seat it firmly against the powder charge.

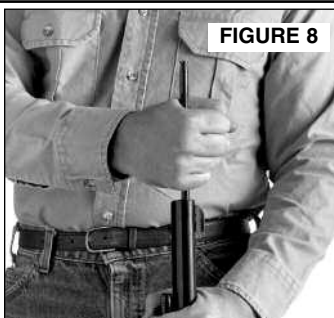

**FIGURE 8**

**Figure 9**

Once the projectile is seated firmly against the powder charge, mark your ramrod to indicate the correct loaded depth of the powder plus the projectile. This will allow you to ensure that each projectile is seated to the same depth before firing. Re-mark the ramrod each time you adjust the powder charge or change projectiles.

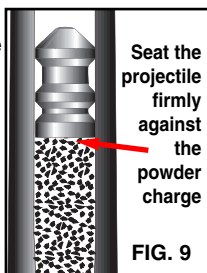

**Figure 10**

When you arrive at the desired charge, mark the ramrod so you have a permanent reference mark. When the powder charge or projectile are then changed, the reference mark should also be changed to indicate the new correct load length.



**WARNING: NEVER FIRE A MUZZLELOADER UNLESS YOU ARE SURE THE PROJECTILE IS PROPERLY SEATED ON THE POWDER CHARGE AND THE RAMROD HAS BEEN REMOVED FROM THE BORE. SHOOTERS SHOULD BEAR IN MIND THAT THE MUZZLELOADING PROJECTILE IS NOT CRIMPED INTO POSITION AS IS THE FIXED CARTRIDGE PROJECTILE. IF A PROJECTILE DOES NOT FIT TIGHTLY THEN JARRING OR MOVEMENT OF THE FIREARM CAN CAUSE IT TO MOVE FORWARD IN A MUZZLELOADER. IF THE FIREARM IS FIRED WHEN A PROJECTILE IS FORWARD OR OFF THE POWDER CHARGE, OR THE RAMROD IS STILL IN THE BORE, THEN THE PROJECTILE OR RAMROD MAY ACT AS A BORE OBSTRUCTION. THIS CAN CAUSE A RUPTURED OR BURST BARREL. A RUPTURED OR BURST BARREL MAY CAUSE INJURY AND/OR DEATH TO THE SHOOTER OR BYSTANDERS AND DAMAGE TO PROPERTY. IF, DUE TO FOULING, A BULLET OR BALL BECOMES LODGED PART WAY DOWN THE BARREL, THE FIREARM MUST BE DISASSEMBLED AND THE CHARGE REMOVED. SEE SECTION ON "CLEANING". ALSO SEE SECTION ON "UNLOADING AND UNCHARGING".**



# PATCHING THE ROUND BALL



**TO SHOOT PROPERLY, THE ROUND BALL MUST BE TIGHTLY PATCHED. IF THE ROUND BALL IS NOT TIGHTLY PATCHED, IT MAY, BY MOVEMENT OF THE FIREARM, WORK ITS WAY OFF THE POWDER CHARGE AND UP THE BORE. UNDER SUCH A CONDITION THE BALL WILL ACT AS A BARREL OBSTRUCTION AND FIRING CAN CAUSE INJURY AND/OR DEATH TO THE SHOOTER OR BY-STANDERS AND DAMAGE TO PROPERTY.**

- It is the job of the lubricated cloth patch to hold the ball tightly against the powder charge until firing and to securely grip both the ball and the rifling so as to transfer the spin of the rifling to the projectile itself. If the patch fits too loosely, the ball will not spin and its flight will be unstable (Figure 11).

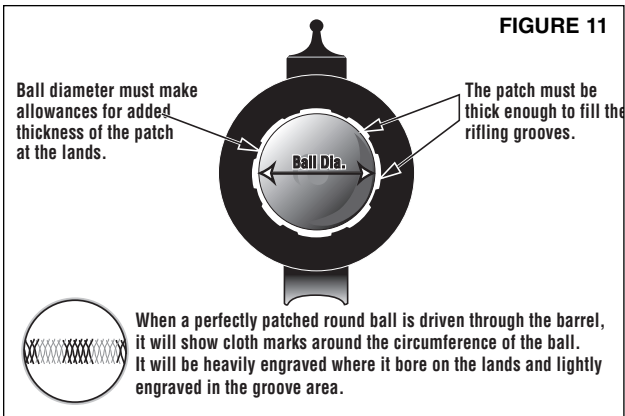

- When shooting a muzzleloading firearm, recover a few of the fired patches and check their condition. Fired patches can usually be found lying on the ground about 10 yards in front of the muzzle. The following illustration will help you to determine whether your patch and/or lubricant is doing its job (Figure 12).

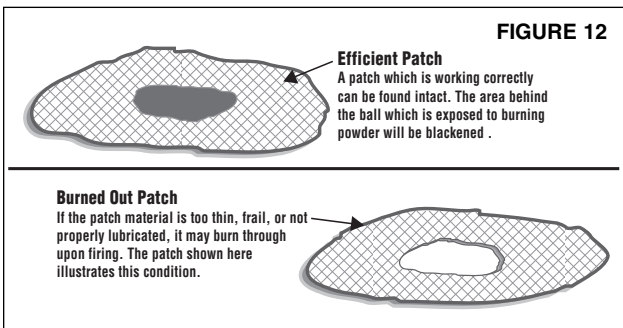

## PATCHING THE ROUND BALL CONT'D

• Lubricant is required to ease loading and prevent the patch material from burning. Thompson/Center recommends the use of patches lubricated with T/C's Natural Lube 1000 Plus Bore Butter™.



**DO NOT USE ANY TYPE OF PLASTIC PATCH OR SABOT WITH A ROUND BALL IN ANY THOMPSON/CENTER FIREARM. WHEN SUCH PATCHES OR SABOTS ARE USED, IT IS POSSIBLE, EVEN UNDER OPTIMUM TOLERANCE CONDITIONS, FOR THE BALL AND PATCH OR SABOT TO DISENGAGE THEMSELVES FROM EACH OTHER. THIS RESULTS IN THE BALL MOVING FORWARD (LEAVING AIR SPACE BETWEEN THE PATCH OR SABOT AND THE BALL). UNDER SUCH CONDITIONS, THE BALL WILL ACT AS A BARREL OBSTRUCTION AND FIRING CAN RESULT IN INJURY AND/OR DEATH TO THE SHOOTER OR BYSTANDERS AND DAMAGE TO PROPERTY.**

**TO LOAD A ROUND BALL WITH A CLOTH PATCH, PROCEED AS FOLLOWS:**

• Lay a lubricated cloth patch over the muzzle and place the round ball in the center of the patch.

• Place the stubby end of the bullet starter on the top of the ball, as shown in Figure 13, and apply pressure until the ball starts into the barrel. A tightly patched ball will require a good deal of pressure and it starts suddenly. It will usually “snap” smartly into the barrel flush with the muzzle.

• Start the ball with the stubby end of the Bullet Starter (Figure 13). A tight fitting combination will load with some difficulty. Never attempt to start the ball with the ramrod. Used improperly the ramrod could break and possibly injure the person loading the firearm.

• Once the ball is started into the barrel, reverse the bullet starter as shown (Figure 14), and place the rod end on the top of the ball. With a sharp blow of the hand, drive the ball down about four inches into the barrel. The ball and patch have now been formed to the rifling and will (if the bore is not fouled) load easily the rest of the way down the bore until it rests firmly on the powder charge.

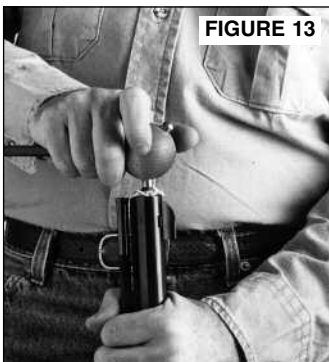

FIGURE 13

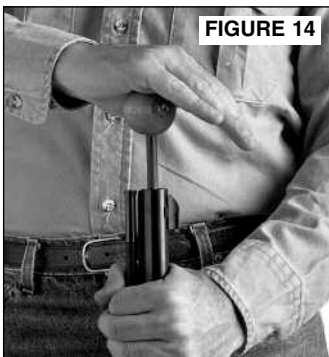

FIGURE 14

## PATCHING THE ROUND BALL CONT'D

- Using the ramrod, push the ball the remainder of the way down the barrel until it firmly contacts the powder charge (Figure 15). Seat the ball firmly against the powder charge (Figure 16) but do not pound on it. Pounding on the ramrod will deform the ball. A deformed ball will not shoot accurately. Try to load and seat each patched lead ball with the same amount of pressure, shot after shot.



FIGURE 15

NOTE: With successive shots, fouling in the bore may build up in sufficient quantity to make loading more difficult, or even impossible. If, for any reason you experience progressively more difficult loading due to buildup of fouling, you must clean the bore, or safe loading will become impossible. See the section on "Cleaning".

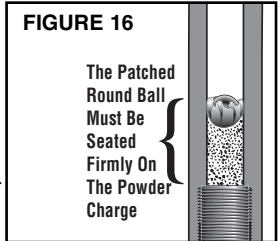

FIGURE 16

The Patched Round Ball Must Be Seated Firmly On The Powder Charge

- Use the ramrod to push the ball down the barrel and to seat it against the charge.
- Once the patched round ball has been loaded, carefully mark your ramrod at the muzzle. A reference mark on the ramrod will allow you to ensure that all the future projectiles are seated to the same depth (Figure 17).

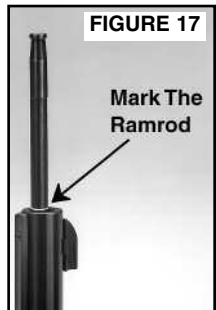

FIGURE 17

Mark The Ramrod

- Remove the ramrod from the bore and return it to the thimbles.

---

# **PRIMING THE T/C NORTHWEST EXPLORER**

---



**WARNING: DO NOT PRIME THE FIREARM UNTIL YOU ARE ACTUALLY READY TO FIRE AND YOU HAVE DOUBLE CHECKED TO ENSURE THAT THE RAMROD HAS BEEN REMOVED FROM THE BORE. THOMPSON/CENTER DOES NOT RECOMMEND PRIMING THE FIREARM UNTIL THE INSTANT BEFORE FIRING. CARRYING A CHARGED, PRIMED T/C NORTHWEST EXPLORER CAN BE DANGEROUS. ACCIDENTAL DISCHARGE IS A CONSTANT HAZARD WHICH, IF IT OCCURS, CAN CAUSE INJURY AND/OR DEATH TO THE SHOOTER OR BYSTANDERS AND DAMAGE TO PROPERTY. THE ONLY SAFE WAY TO GUARD AGAINST AN ACCIDENTAL DISCHARGE IS TO CARRY YOUR T/C NORTHWEST EXPLORER UNPRIMED, WITH THE HAMMER IN THE "AT REST" POSITION AND THE MUZZLE POINTED DOWNRANGE AWAY FROM YOURSELF, BYSTANDERS OR PROPERTY.**

If you have followed the preceding instructions in this manual, your firearm will now be charged with Black Powder or an approved Black Powder substitute such as Pyrodex<sup>®</sup> and a projectile will be firmly seated against the powder charge. The ramrod will be returned to the thimbles under the barrel and your ramrod will be marked to the exact seating depth of the powder/projectile combination that you are using - allowing you to ensure that each future projectile is also seated to the same depth in the bore.

The T/C Northwest Explorer muzzleloading rifle uses a No.11 percussion cap for ignition.

With the muzzle pointed in a safe direction, open the action by pivoting the trigger guard down and forward.

---

## ***PRIMING THE T/C NORTHWEST EXPLORER CONT'D***

---

WHEN YOU ARE READY TO FIRE YOUR T/C NORTHWEST EXPLORER, OPEN THE ACTION AND PRIME IT - BY PLACING A No.11 PERCUSSION CAP ON THE NIPPLE.

Handling No.11 percussion caps can be made easier with any of the priming tools that Thompson/Center offers. To prime the firearm, place the No.11 percussion cap onto the nipple.

If you decide not to fire; make sure the firearm is always pointed in a safe direction, lower the hammer carefully to the "AT REST" position and remove the No.11 percussion cap from the nipple.

---

# **FIRING THE T/C NORTHWEST EXPLORER**

---



**WARNING: ALWAYS KEEP THE MUZZLE POINTED IN A SAFE DIRECTION.**



**WARNING: WEAR EYE AND EAR PROTECTION SPECIFIED FOR FIREARM USE EVERY TIME YOU DISCHARGE YOUR FIREARM. MAKE SURE OTHERS IN THE VICINITY OF WHERE YOU WILL BE SHOOTING DO SO AS WELL.**



**WARNING: ALWAYS HAVE ADEQUATE VENTILATION. CLEANING FIREARMS IN POORLY VENTILATED AREAS, DISCHARGING FIREARMS, OR HANDLING AMMUNITION AND LOADING COMPONENTS MAY RESULT IN EXPOSURE TO LEAD AND OTHER SUBSTANCES KNOWN TO CAUSE BIRTH DEFECTS, REPRODUCTIVE HARM AND OTHER SERIOUS PHYSICAL INJURY. WASH HANDS THOROUGHLY AFTER EXPOSURE.**



**WARNING: NEVER RELY ON MECHANICAL FEATURES ALONE. ONLY YOUR SAFE FIREARM HANDLING WILL ENSURE THE SAFE USE OF YOUR FIREARM. THIS IS YOUR RESPONSIBILITY.**



**WARNING: WHEN FIRING THE T/C NORTHWEST EXPLORER, HOLD IT FIRMLY, ALLOWING YOUR BODY WEIGHT TO ABSORB AND BUFFER THE FORCE OF THE RECOIL. AN IMPROPERLY HELD FIREARM CAN CAUSE POSSIBLE INJURY AND/OR BRUISING.**

The instant before firing, you must prime the T/C Northwest Explorer muzzleloading rifle. With the muzzle pointed in a safe direction, open the action and press a No.11 percussion cap onto the nipple. Tip the breech back up via the trigger guard and lock it closed - at this point the firearm is ready to fire.



**FIGURE 18**

- Grasp rifle firmly with the trigger finger resting along and outside of the trigger guard.
- Raise firearm and pull the stock firmly into the shoulder.
- Draw the hammer back to the full rearward “COCKED” position (Figure 19).
- The firearm will now fire when pressure is applied to the trigger.

## FIRING THE T/C NORTHWEST EXPLORER CONT'D

- Place your finger on the trigger and squeeze until the firearm fires.
- To reload, see the Section on "CHARGING".

**WARNING: IF THE FIREARM IS NO LONGER GOING TO BE USED, UNCHARGE IT BY FIRING IT INTO A SUITABLE BACKSTOP OR PULL THE CHARGE BEFORE RETURNING IT TO YOUR VEHICLE, CAMP OR HOME (SEE SECTION ON "UNLOADING"). AN ACCIDENTAL DISCHARGE CAN CAUSE INJURY AND/OR DEATH TO THE SHOOTER OR BYSTANDERS AND DAMAGE TO PROPERTY.**

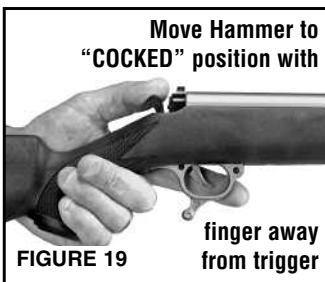

If you decide not to fire; first, make sure the firearm is always pointed in a safe direction - then you must carefully lower the hammer from the "Cocked" position to the "At Rest" position. To do this, hold your thumb securely on the hammer so it cannot drop freely - then pull the trigger back (only long enough to disengage the hammer from the sear) (FIGURE 20) and allow the hammer to move forward slowly - with your trigger finger now fully away from the trigger - until the hammer resides in the "At Rest" position (Figure 21). Open the breech and remove the No.11 percussion cap from the nipple.



**WARNING: IF YOUR FIREARM GIVES ANY INDICATION THAT IT IS NOT PERFORMING PROPERLY OR THE OPERATION OF YOUR FIREARM HAS CHANGED "THE WAY IT FEELS OR SOUNDS", STOP FIRING. MAKE SURE THE FIREARM IS POINTED IN A SAFE DIRECTION, UNLOAD THE FIREARM AND HAVE IT INSPECTED BY A FACTORY TECHNICIAN. CALL THOMPSON/CENTER CUSTOMER SUPPORT @ 603-330-5659.**

---

# UNLOADING AND UNCHARGING

---

## UNLOADING A CHARGE FROM THE T/C NORTHWEST EXPLORER MUZZLELOADER

Under normal conditions the T/C Northwest Explorer muzzleloader is unloaded simply by firing it into a suitable and safe backstop. There are, however, some conditions under which the firearm cannot be fired and the charge must be removed manually.

SOME OF THE MOST COMMON CONDITIONS ARE AS FOLLOWS:

- If the projectile is not seated firmly against the powder charge, stop immediately! Do not attempt to fire the firearm. You must remove the charge and then clean the barrel.
- If the T/C Northwest Explorer muzzleloader is loaded in a proper manner yet fails to fire after repeated priming and clearing of the ignition channel.
- If you are at a location that is unsuitable for discharging the firearm before transporting it.



**WARNING: ALWAYS KEEP THE MUZZLE POINTED IN A SAFE DIRECTION.**



**WARNING: NEVER ATTEMPT TO PULL A CHARGE FROM YOUR MUZZLELOADER UNTIL YOU ARE ABSOLUTELY CERTAIN THAT THE FIREARM IS UNPRIMED. WHILE IN THE PROCESS OF PULLING THE CHARGE, DO NOT SMOKE, OR BE NEAR ANYONE ELSE WHO IS SMOKING; THE SPARK FROM A LIGHTED CIGARETTE, CIGAR, OR PIPE CAN IGNITE BLACK POWDER, A BLACK POWDER SUBSTITUTE OR CAPS AND PRIMERS. ANY EXTERNAL HEAT SOURCE CAN IGNITE YOUR CHARGE, CAUSING AN EXPLOSION, WHICH COULD RESULT IN INJURY AND/OR DEATH TO THE SHOOTER OR BYSTANDERS AND DAMAGE TO PROPERTY.**

To remove a charge from your T/C Northwest Explorer muzzleloader it will be necessary to take the following steps:

- Open the action and make sure that the firearm is uncapped.
- Remove the breech plug.
- Once the breech plug has been removed, point the muzzle up. Gravity should then cause the pellets or the loose powder to drop out. The bullet can then be poked out of the bore with your ramrod. To push the bullet fully out of the barrel, it will be necessary to add the extended super jag (which came with your rifle) to your ramrod, or, you may use a longer “range rod” if you have access to one.



---

## **UNLOADING & UNCHARGING CONT'D**

---

- If the powder does not come out as a result of gravity, push the entire charge out from the muzzle end with your ramrod and the installed ramrod extension. If that isn't possible, you should then pour water into the breech area of the barrel to fully saturate (and liquify) the pellets or powder. After the powder is removed, push the bullet out with your ramrod inserted from the muzzle (with the ramrod extension installed).

### **If you can't remove the breech plug at this point;**

If you can't remove the breech plug in order to unload the charge, it will be necessary to submerge the breech section of the barrel in a pail or bucket of water.

Disassembly of the T/C Northwest Explorer will be necessary.

- Check to make sure the firearm is unprimed by opening the action and removing the primer from the breech plug.
- Detach the barrel/action assembly from the stock as detailed in the **Disassembly Section** of this manual.
- Once the barrel/action assembly is detached - submerge the barrel breech section of the barrel in a pail of water (hot water if possible). Make certain that at least 8" of the breech section is submerged for at least 1/2 hour.
- Once the powder has been soaked for 1/2 hour and rendered inert, try pulling the projectile from the bore by using your ramrod (or a range rod) with a bullet puller. Screw the bullet puller onto your rod, insert from the muzzle end, and when you make contact with the projectile, turn the rod clockwise, screwing the bullet puller into the projectile. Once screwed into the projectile, pull the projectile out.
- If, for any reason, you are unable to remove the charge in the manner recommended, soak the barrel again. Squirt oil into the primer pocket of the breech plug and into the barrel's breech area in order to ensure that the powder charge is completely inert, (if you were to use water only - it will just dry out over a period of time), and return the barrel to the Customer Service Department with a letter describing the problem.

---

# **FIELD CLEANING**

---



**WARNING: ALWAYS KEEP THE MUZZLE POINTED IN A SAFE DIRECTION.**



**WARNING: WEAR SAFETY GLASSES EVERY TIME YOU ASSEMBLE OR DISASSEMBLE YOUR FIREARM AND ATTEMPT CLEANING OR MAINTENANCE.**



**NEVER ATTEMPT TO CLEAN A CHARGED OR PRIMED MUZZLELOADING FIREARM. AN ACCIDENTAL DISCHARGE CAN CAUSE INJURY AND/OR DEATH TO THE SHOOTER OR BYSTANDERS AND DAMAGE TO PROPERTY.**



**WARNING: ALWAYS HAVE ADEQUATE VENTILATION. CLEANING FIREARMS IN POORLY VENTILATED AREAS, DISCHARGING FIREARMS, OR HANDLING AMMUNITION AND LOADING COMPONENTS MAY RESULT IN EXPOSURE TO LEAD AND OTHER SUBSTANCES KNOWN TO CAUSE BIRTH DEFECTS, REPRODUCTIVE HARM AND OTHER SERIOUS PHYSICAL INJURY. WASH HANDS THOROUGHLY AFTER EXPOSURE.**

**NOTE:** Residue from burned Black Powder and Black Powder substitutes such as Pyrodex is very corrosive. The fouling or residue left over after firing your muzzleloading firearm can be destructive to firearm's parts. Leaving your firearm uncleaned with this fouling present can lead to a ruined firearm, as the firearm's parts will rust and oxidize quickly.

The build-up of fouling from shot to shot will produce shot to shot increases in pressure that will greatly affect accuracy. The bullet lubricant used, the amount of powder in the charge, and the projectile used will all affect the amount of fouling produced with each shot. Eventually, if not cleaned, the muzzleloading firearm will become impossible to load properly. Driven part way down the bore and blocked by fouling, a projectile may "hang up" and refuse to budge further.



**WARNING: A PROJECTILE WHICH IS SEATED ONLY PART WAY DOWN THE BARREL SETS UP A HIGHLY DANGEROUS CONDITION WHICH MAY CAUSE A BURST BARREL AND INJURY AND/OR DEATH TO THE SHOOTER OR BYSTANDER AND DAMAGE TO PROPERTY. THE PROJECTILE MUST BE SEATED FIRMLY AGAINST THE POWDER CHARGE. IF THE PROJECTILE IS NOT SEATED AGAINST THE POWDER CHARGE THE FIREARM MUST BE DISASSEMBLED AND THE CHARGE REMOVED (SEE SECTION ON "PULLING A CHARGE"). NEVER FIRE A MUZZLELOADING FIREARM UNLESS THE PROJECTILE IS FIRMLY SEATED ON THE POWDER CHARGE.**

## FIELD CLEANING CONT'D

The T/C Northwest Explorer muzzle-loader was supplied with a cleaning jag which is the proper size for cleaning the firearm. Use commercial cleaning patches (round or square) or pieces of cotton clothing to clean the bore.

Use the cleaning jag that was provided with the T/C Northwest Explorer, and a cleaning patch saturated with a bore cleaner like Thompson/Center's No.13™ Solvent. Run the saturated patch up and down the bore a few times - to remove the fouling (FIGS. 22 - 23).

T/C's No.13™ Solvent is specifically formulated for cleaning fouling caused by Black Powder or Pyrodex®.

After removing the fouling from the bore, follow up with a few dry patches to thoroughly dry the bore.

Clean the breech assembly with a soft bristle brush dampened with some solvent. When the breech assembly is dry, lightly oil it.

Use a pressurized moisture displacing oil to clean and lubricate the firing pin within the breech block - as shown (Figure 24).

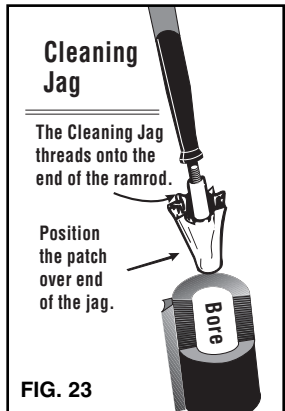

# THOROUGH CLEANING



**WARNING: ALWAYS KEEP THE MUZZLE POINTED IN A SAFE DIRECTION.**



**WARNING: WEAR SAFETY GLASSES EVERY TIME YOU ASSEMBLE OR DISASSEMBLE YOUR FIREARM AND ATTEMPT CLEANING OR MAINTENANCE.**



**WARNING: NEVER ATTEMPT TO CLEAN A CHARGED OR PRIMED MUZZLELOADING FIREARM. AN ACCIDENTAL DISCHARGE CAN CAUSE INJURY AND/OR DEATH TO THE SHOOTER OR BYSTANDERS AND DAMAGE TO PROPERTY.**



**WARNING: DO NOT ALTER, MODIFY OR REPLACE ANY OF THE PARTS OF YOUR FIREARM UNLESS THIS WORK IS PERFORMED BY A QUALIFIED GUNSMITH USING GENUINE THOMPSON/CENTER PARTS. IF YOU DO OTHERWISE, IMPROPER FUNCTIONING MAY OCCUR AND SERIOUS INJURY MAY RESULT.**



**WARNING: ALWAYS HAVE ADEQUATE VENTILATION. CLEANING FIREARMS IN POORLY VENTILATED AREAS, DISCHARGING FIREARMS, OR HANDLING AMMUNITION AND LOADING COMPONENTS MAY RESULT IN EXPOSURE TO LEAD AND OTHER SUBSTANCES KNOWN TO CAUSE BIRTH DEFECTS, REPRODUCTIVE HARM AND OTHER SERIOUS PHYSICAL INJURY. WASH HANDS THOROUGHLY AFTER EXPOSURE.**

Proper cleaning is essential to ensure the proper functioning of your firearm.

Your firearm is a precision instrument. To ensure reliable function it is necessary to follow a routine maintenance procedure. When you are finished shooting for the day or for the season and plan to store the T/C Northwest Explorer muzzleloader away, you must clean the firearm thoroughly. Follow these instructions for thorough cleaning:

Tip the breech open and be certain that there is no primer on the nipple. Then remove the breech plug.

The breech plug is removed from the barrel by turning it counter-clockwise (as viewed from the breech end of the barrel) using the wrench that was supplied with the firearm and then grasping it with your fingers (FIGS. 25 & 26) .

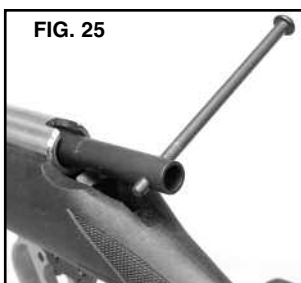

## THOROUGH CLEANING CONT'D

Once removed, the breech plug should be scrubbed free of fouling and then the threads should be lubricated with an anti-seize lubricant like T/C's Super Lube, before reinstallation. The threads inside the breech end of the barrel must also be well cleaned with a stiff brush and solvent and then dried and lubricated with anti-seize lubricant.

The nipple can be removed from the breech plug for cleaning or replacement as needed (Figs. 27a & 27b).

Next in the cleaning process; fill a pan with hot soapy water. Submerge the muzzle end of the barrel in the water and push a wet patch down the barrel (from the breech end) on the end of your ramrod that has a jag installed on it (a jag comes with T/C muzzleloaders from the factory). Pump the ramrod and patch up and down in the barrel. This will draw water into the barrel and flush out the fouling. When the barrel is clean, wipe off any excess water and allow it to dry.

Thoroughly wipe any powder residue from the frame assembly. Dry the parts thoroughly and lubricate them lightly to prevent rust and corrosion.

Use a pressurized moisture displacing oil to clean and lubricate the firing pin within the breech block - as shown (Figure 28).

After cleaning your T/C Northwest Explorer muzzleloader, it is recommended that you lightly lubricate the metal surfaces of the rifle. Do not use heavy grease or oil, as during cold weather, excessive lube may congeal and slow or stop the hammer fall when the trigger is pulled.

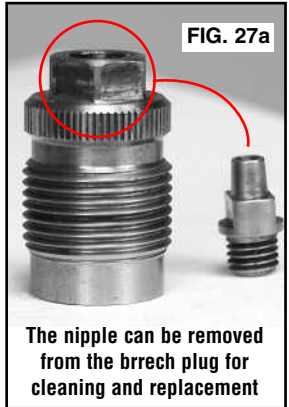

**⚠ USE ONLY THOMPSON/CENTER NIPPLES IN YOUR THOMPSON/ CENTER FIREARMS. UNAUTHORIZED REPLACEMENTS CAN CREATE A DANGEROUS CONDITION. BE CERTAIN THAT THE THREADS MESH PROPERLY (NOT CROSSTHREADED) AND ENSURE THAT THE NIPPLE IS SNUG BEFORE LOADING AND FIRING.**

---

## **THOROUGH CLEANING CONT'D**

---

With the barrel completely dry, lightly lubricate the bore with a quality firearm lubricant or, in keeping with the all-natural method, T/C's Natural Lube 1000 Plus Bore Butter™. Re-install the breech plug, making sure that you have lubricated all of the threads with an anti-seize lubricant like T/C's Super Lube. The breech plug should be threaded into place by turning it clockwise with the breech plug wrench - until it is seated. Screw the breech plug in carefully. Be certain that the threads mesh properly (not cross-threaded) and ensure that the breech plug is snug.



**IMPROPER TYPE OR INSTALLATION OF BREECH PLUGS CAN CAUSE INJURY AND/OR DEATH TO THE SHOOTER OR BYSTANDERS AND DAMAGE TO PROPERTY.**

Lubricate the threads inside the breech area of the barrel with anti-seize lubricant.

After your T/C Northwest Explorer muzzleloader breech plug has been reinstalled, check for proper functioning of the barrel and the hammer/trigger mechanism prior to loading and firing.

If the T/C Northwest Explorer muzzleloader has become very dirty due to extensive firing, the shooter may need to disassemble the rifle further than just removing the breech plug. If this happens, follow the instructions in the section on disassembly:

### **CAUTION:**

Always follow the instructions provided with your firearm cleaner and firearm lubricant.

### **CAUTION:**

Some cleaners can cause damage to your firearms. You should avoid prolonged solvent immersion and prolonged ultrasonic cleaning of your firearm. Choice of solvent should be restricted to those products specifically developed for firearms maintenance. Damage to a firearm's finish may occur if these cautions are ignored. Ammoniated solvents or other strong alkaline solvents, should not be used on any Thompson/Center firearm. As a rule of thumb, if you would be comfortable applying the solvent of your choice to the finish of your automobile, it will probably be safe for use on your firearm.

# DISASSEMBLY OF THE T/C NORTHWEST EXPLORER MUZZLELOADER

**WARNING: MAKE SURE THAT THE MUZZLELOADER IS UNCHARGED AND UNPRIMED. TO ENSURE THAT THE FIREARM IS UNCHARGED AND UNPRIMED, LOWER THE TRIGGER GUARD AND TIP THE BREECH DOWN. THIS WILL NIPPLE IN THE BREECH PLUG. MAKE SURE THERE IS NO CAP SEATED ON THE NIPPLE. NEXT, HOLDING THE MUZZLE UP TO THE LIGHT, LOOK THROUGH THE IGNITION FIRE CHANNEL FROM THE BREECH END TO MAKE SURE YOU CAN SEE THROUGH IT. IF YOU CANNOT SEE THROUGH IT, EITHER THE FIREARM IS CHARGED OR THE IGNITION FIRE CHANNEL IS OBSTRUCTED AND IT WILL BE NECESSARY FOR YOU TO REMOVE THE BREECH PLUG AS DETAILED IN THE PREVIOUS SECTION ON THOROUGH CLEANING. IF YOU CAN SEE LIGHT, PROCEED AS FOLLOWS:**

The T/C Northwest Explorer Muzzleloader breaks down into two basic groups of parts as shown below:

- The Barrel and Action Assembly. This assembly is held in the stock by two stock screws; one is located about 1" in front of the trigger guard, and the other is approximately 4" ahead of the first.

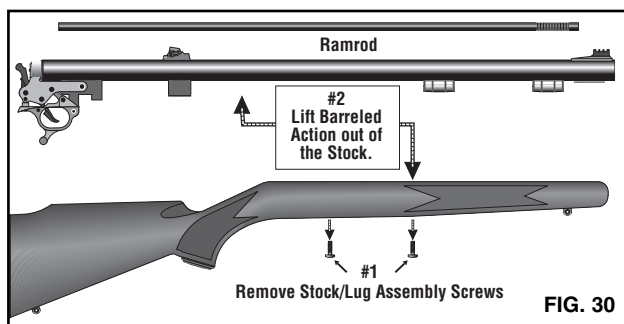
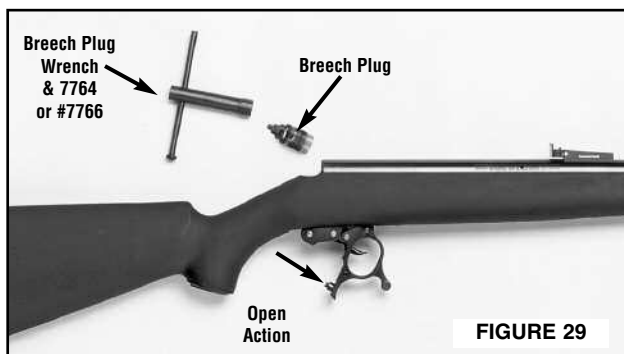

---

## **DISASSEMBLY CONT'D**

---

- The Stock Assembly.
- **NEVER DISASSEMBLE YOUR FIREARM** beyond the procedures outlined in this manual. Improper disassembly or re-assembly of your firearm may be dangerous and can lead to serious injury or death.

### **TAKEDOWN OF THE T/C NORTHWEST EXPLORER MUZZLELOADING RIFLE**

- Make sure that the firearm is unprimed and uncharged.
- Remove the ramrod from the thimble(s).
- Lower the swinging breech block to open the action by pivoting the trigger guard forward. This will expose the nipple in the breech plug.
- Make sure there is no cap seated. Next, holding the muzzle up to the light, look through the ignition fire channel to make sure you can see through it. If you can not see through it, it is charged or the channel is obstructed and it will be necessary for you to remove the breech plug.
- Close the swinging breech and remove both the front and rear stock/lug assembly screws by turning them counter clockwise. (As viewed from the bottom of the firearm)
- The barrel/action assembly may now be lifted out of the stock.
- Open the breech, and insert the breech plug wrench onto the breech plug. Turn counter clockwise to unscrew the breech plug. You may have to exert some initial force in order to “break” the gas seal, which formed when the breech plug was originally “snugged” to the barrel during installation. There will be initial resistance to overcome.

If you need to hold the barrel more firmly than you can with just your hand, a crescent wrench or vise on the barrel lug will supply the needed holding power. This procedure will give you the necessary leverage to “break” the gas seal which was formed when the breech plug was originally “snugged” to the barrel during installation. There will be initial resistance between these parts which must be overcome.



---

## **DISASSEMBLY CONT'D**

---

- To reassemble, reverse these steps, making sure that you check for proper functioning of the trigger/hammer mechanism prior to loading and firing. The breech plug of the T/C Northwest Explorer muzzleloader should be seated in the barrel until it is “snug”. “Snug” is defined as being as tight as you can turn it into the barrel by using the breech plug wrench and turning it clockwise, while holding the barrel in your hand. When you can no longer grip the barrel, and it turns in your hand, the breech plug is “snug”.

The breech plug should be threaded into place by turning it clockwise with the breech plug wrench - until it is seated. Screw the breech plug in carefully. Be certain that the threads mesh properly (are not cross-threaded) and ensure that the breech plug is snug.

Figures 29 and 30 show the extent to which the T/C Northwest Explorer should be disassembled. If other service is required, contact the Thompson/Center Customer Service Department.

---

# **SIGHT ADJUSTMENT**

---



**WARNING: ALWAYS ENSURE THAT THE FIREARM IS UNCHARGED AND UNPRIMED BEFORE ATTEMPTING ANY ADJUSTMENTS. FAILURE TO DO THIS CAN CAUSE PERSONAL INJURY OR DEATH TO YOU OR OTHERS.**

Move the elevation slide up or down its ramp to change the vertical point of bullet impact (move it up to raise the shot's point of impact). To do this, turn the Elevation Adjustment Lock Screw (Figure 31) counter-clockwise (as viewed from the receiver end) to loosen it - then move the slide up or down the ramp (using the graduation lines as a guide). Re-tighten the Lock Screw after making adjustments.

To adjust the windage it is necessary to slide the rear sight blade assembly left or right after loosening the Windage Adjustment Lock Screw.

Move the rear sight blade in the direction you want your shots to hit-- (Example; moving the sight blade to the right moves your shots to the right and to the left move the shots to the left). Retighten Lock Screw after adjusting.

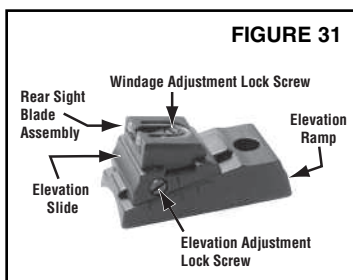

---

# **LIMITED LIFETIME WARRANTY**

---

This warranty is granted by Thompson/Center Arms Company, Inc. This warranty, which shall last for the Lifetime of the original owner of any factory finished firearm, is established by the return of the Thompson/Center Arms authorized warranty card within thirty (30) days of purchase of such firearm. With respect to such firearm, this warranty supersedes any and all other warranties.

Thompson/Center Arms firearms are warranted to be free from defects in material and workmanship. Any such defects of which Thompson/Center Arms receives written notice by the original owner will be remedied by Thompson/Center Arms without charge within a reasonable time after such notification and delivery of the firearm as provided below.

Warranty claims (in writing) and the firearm or part thereof concerned should be delivered, postage prepaid, to the factory at Thompson/Center, 400 North Main Street, Rochester, New Hampshire, 03867. In addition, a copy of the bill of sale in the owner's name, or, where applicable, a copy of ATF Form 4473 indicating date of purchase must be included. It is important that the owner comply with all applicable federal, state and local laws and regulations in the shipment of firearms to Thompson/Center Arms.

Warranty claims should state the model and, where applicable, the serial number of the firearm concerned and the description of the difficulty experienced. It is recommended that shipments be insured by the owner, since Thompson/Center Arms will accept no responsibility for loss or damage in transit. Transportation and insurance charges for return to the owner will be paid by Thompson/Center Arms if the claim is covered by this warranty.

**UNDER NO CIRCUMSTANCES SHALL THOMPSON/CENTER ARMS BE RESPONSIBLE FOR INCIDENTAL OR CONSEQUENTIAL DAMAGES WITH RESPECT TO ECONOMIC LOSS, INJURY, DEATH OR PROPERTY DAMAGE, WHETHER AS A RESULT OF BREACH OF THIS WARRANTY, NEGLIGENCE OR OTHERWISE.**

Some States do not allow the exclusion or limitation of incidental or consequential damages, so the above limitation or exclusion may not apply to you.

Thompson/Center Arms will not be responsible for:

- Defects or malfunctions resulting from careless handling, unauthorized adjustments or modifications made or attempted by anyone other than a qualified gunsmith following Thompson/Center Arms authorized procedures, or failure to follow the instructions in the Thompson/Center Arms Safety & Instruction manual.

---

## **LIMITED LIFETIME WARRANTY CONT'D**

---

- Use of defective or improper ammunition and/or propellant, corrosion, neglect, abuse, ordinary wear and tear, or unreasonable use.
- Use of replacement parts, including but not limited to barrels and springs, other than Thompson/Center Arms factory or authorized parts.
- Criminal misuse, negligence, or use under the influence of drugs or alcohol.

Services performed by the Thompson/Center Arms Custom Shop and/or Repair Department do not void this warranty. This warranty gives you specific legal rights, and you may also have other rights which vary from State to State.

Note: All liability is excluded in the event that the instructions in the Thompson/Center Arms Safety and Instruction manual are not observed.

---

## **CONTACT & SHIPPING FOR SERVICE**

---

**Shipping Address:** Thompson/Center  
400 North Main St.  
Rochester, New Hampshire 03867

Should your Thompson/Center firearm require service, it should be returned to the Thompson/Center factory.

- Call or e-mail the Customer Service Dept. for authorization and shipping instructions.
- Ensure that both the magazine and chamber are unloaded.
- **Do not attempt to ship a firearm via US Postal Service; only federally licensed dealers may ship a firearm by US Postal Service.**
- **DO NOT SHIP ANY AMMUNITION.**
- Enclose a letter which includes your full name and address (no P.O. Boxes, please), daytime telephone number, e-mail address, the serial number of the firearm, and details of the problem experienced (stating the brand and type of ammunition used when the problem occurred) or work desired.
- Record the serial number before shipping, in case you wish to check on the repair status of your firearm.

---

## **CONTACT & SHIPPING FOR SERVICE CONT'D**

---

- Please remove all custom parts and accessories, such as stocks, special sights and scopes, or slings from your firearm before returning.
- Place the firearm in its original case or in a similarly secure container and pack it securely.
- The package must **NOT** bear any markings which indicate the identity of the contents.
- It is most important that you comply with federal, state, and local laws and regulations. The following guidelines are meant to help, but you must seek assistance from the appropriate authorities if necessary.
- If your firearm must be replaced, it *may* be necessary to ship the replacement to a dealer rather than directly to you. You *may* be requested to furnish a signed FFL (Federal Firearms License) from your dealer in such an instance.
- Warranty repair work will begin upon receipt and examination of the firearm. In the case of repairs or work not covered by the warranty, a quotation covering the cost of the work plus round trip transportation charges will be sent to you. Repairs or modification will begin upon receipt of payment.



**WARNING: YOU MAY PURCHASE ACCESSORIES FOR YOUR THOMPSON/CENTER FIREARM. YOU MUST HAVE SOME OF THESE PARTS INSTALLED BY A GUNSMITH QUALIFIED TO PERFORM SERVICE ON THOMPSON/CENTER FIREARMS. NEVER ATTEMPT TO MODIFY YOUR FIREARM OR INSTALL REPLACEMENT PARTS IN YOUR FIREARM. ALWAYS USE A QUALIFIED THOMPSON/CENTER GUNSMITH EVEN IF THE REPAIR SEEMS SIMPLE.**

---

# **LOAD COMPONENTS**

---



**WARNING: NEVER USE LOADING COMPONENTS NOT SPECIFICALLY REFERENCED IN THIS MANUAL. FAILURE TO FOLLOW THIS RULE MAY CAUSE EXCESSIVE PRESSURE WHICH CAN DAMAGE OR EVEN RUPTURE YOUR FIREARM, CAUSING PERSONAL INJURY, DEATH OR PROPERTY DAMAGE.**

- **USE ONLY BLACK POWDER OR AN APPROVED BLACK POWDER SUBSTITUTE SUCH AS PYRODEX® TO LOAD YOUR MUZZLELOADING FIREARM.** Never use even small amounts of smokeless powder, even if it is black in color. The use of any other propellant may cause injury or death to the shooter or bystanders and damage to property.
- **YOU ARE RESPONSIBLE FOR USING THE CORRECT COMBINATION OF LOAD COMPONENTS IN YOUR T/C NORTHWEST EXPLORER MUZZLELOADER** as detailed in this manual.

NOTE: Different combinations of bullet weight and powder charge can have a major effect on felt recoil. Heavier bullets and heavier powder charges will result in more recoil.



**WARNING: DEATH, SERIOUS INJURY AND DAMAGE CAN RESULT FROM THE USE OF INCORRECT LOAD COMPONENTS.**

---

# **SUGGESTED LOADS FOR THE T/C NORTHWEST EXPLORER**

---

The following charts show recommended charges using Black Powder or a Pyrodex<sup>®</sup> equivalent as the propellant for the T/C Northwest Explorer muzzleloading rifle. Loads are listed by caliber, powder charge and type of projectile.

Note that in each instance a series of charges are listed. More than one charge is shown in each category to illustrate the appropriate powder charge range for that particular caliber, firearm model and projectile.



**WARNING: MAXIMUM LOADS ARE NOT TO BE EXCEEDED NOR IS A SUBSTITUTION OF POWDER OR GRANULATIONS TO BE ATTEMPTED! ONLY USE LOADS THAT ARE LISTED FOR YOUR PARTICULAR CALIBER, MODEL AND BULLET STYLE. FAILURE TO FOLLOW THESE INSTRUCTIONS MAY RESULT IN INJURY AND/OR DEATH TO THE SHOOTER OR BYSTANDERS AND DAMAGE TO PROPERTY.**

- The shooter is instructed to start with the lightest charge listed. As you become familiar with the firearm, increase your charges gradually until you reach your best performing load (most accurate). Thompson/Center Arms is not responsible for loading information printed in sources other than this booklet.

NOTE: All loading data contained in this book is the result of testing by Thompson/Center Arms. Testing was done under carefully controlled conditions with the components specified in the text. 28 inch barrels were used to produce the data (unless otherwise specified).

- Since Thompson/Center has no control over the components or equipment which may be used with this information, no responsibility is implied or assumed for the results obtained.



**WARNING: THE LOADING DATA FOUND IN THIS MANUAL WAS COMPILED USING BLACK POWDER OR GRANULAR (LOOSE) PYRODEX<sup>®</sup> RS AS A PROPELLANT (NO PELLETS). WITH ANY OTHER APPROVED BLACK POWDER SUBSTITUTE FOLLOW THE INSTRUCTIONS SUPPLIED BY THE MANUFACTURER AND HEED ALL WARNINGS AS THEY APPLY TO LOADING AND USAGE OF THAT PRODUCT.**

# **PATCHED .490" ROUND BALL LOADS**

For Use Only With .50 Caliber T/C Northwest Explorer Only Patches Lubricated with Bore Butter™. Use a No.11 cap for ignition		<b>.50 Caliber Rifle Using Black Powder &amp; Pure Lead Round Ball Loads</b>	
.490" Diameter Lead Ball Weight (Grains)	Black Powder Charge (Grains)	Muzzle Velocity (Feet Per Second)	Muzzle Energy (Foot Pounds)
<b>175 Grain Lead Ball</b>	50 grs. FFG	1357 F.P.S.	716 Ft. Lbs.
	60 grs. FFG	1434 F.P.S.	799 Ft. Lbs.
	70 grs. FFG	1643 F.P.S.	1050 Ft. Lbs.
	80 grs. FFG	1838 F.P.S.	1313 Ft. Lbs.
	90 grs. FFG	1950 F.P.S.	1478 Ft. Lbs.
	100 grs. FFG	2052 F.P.S.	1637 Ft. Lbs.
	<b>110 grs. FFG</b>	<b>2135 F.P.S.</b>	<b>1772 Ft. Lbs.</b>
<b>Load Shown in Red is Maximum</b>			

# **LUBRICATED T/C MAXI-BULLET LOADS**

For Use Only With .50 Caliber T/C Northwest Explorer Only Bullets Lubricated with Bore Butter™. Use a No.11 cap for ignition		<b>.50 Caliber Rifle Using Black Powder &amp; Maxi-Ball or Maxi-Hunter Loads</b>	
Use With Bullets Weighing (Grains)	Black Powder Charge (Grains)	Muzzle Velocity (Feet Per Second)	Muzzle Energy (Foot Pounds)
<b>275 Grain Maxi-Hunter or 320 Grain Maxi-Ball Lead Bullet</b>	80 grs. FFG	1408 F.P.S.	1409 Ft. Lbs.
	90 grs. FFG	1462 F.P.S.	1519 Ft. Lbs.
	100 grs. FFG	1511 F.P.S.	1623 Ft. Lbs.
	110 grs. FFG	1588 F.P.S.	1792 Ft. Lbs.
	<b>120 grs. FFG</b>	<b>1632 F.P.S.</b>	<b>1893 Ft. Lbs.</b>
<b>350 Grain Maxi-Hunter or 370 Grain Maxi-Ball Lead Bullet</b>	80 grs. FFG	1344 F.P.S.	1484 Ft. Lbs.
	90 grs. FFG	1426 F.P.S.	1671 Ft. Lbs.
	100 grs. FFG	1478 F.P.S.	1795 Ft. Lbs.
	110 grs. FFG	1535 F.P.S.	1936 Ft. Lbs.
	<b>120 grs. FFG</b>	<b>1556 F.P.S.</b>	<b>1990 Ft. Lbs.</b>
<b>Load Shown in Red is Maximum</b>			

**T/C Mailing Address:**

(for questions & comments)

**Thompson/Center Arms Company, Inc.**

**PO Box 5002**

**Rochester, New Hampshire 03866**

**T/C Shipping Address:**

(for repairs or warranty work)

**Thompson/Center Arms Company, Inc.**

**ATTN: Repair Department**

**400 North Main Street**

**Rochester, New Hampshire 03867**

**Web Address:**

**[www.tcarms.com](http://www.tcarms.com)**

**Customer Service Phone:**

**603-330-5659**