



ROCK ISLAND ARMORY

1911A1 / 1911A2

PISTOL

Owner's Manual

ROCK ISLAND ARMORY

OWNER / USER'S MANUAL
ROCK ISLAND ARMORY
1911A1 / 1911A2
PISTOL

SAFETY, INSTRUCTION AND PARTS MANUAL

As a responsible owner of this firearm, you must read the instructions and warnings in this manual carefully. Before using this firearm, make sure you thoroughly understand all warnings and instructions.

This manual must always be in the firearm's carrying case wherever the owner/user brings it or when it transfers ownership. A copy of this manual is available upon request from:

TWIN PINES, INC.
No. 4 Liwayway Street
San Juan, Metro Manila
Philippines
Tel. (632) 727-5252
Fax (632) 727-5270

This firearm is basically the same in form, parts and function as the US Colt Government Model 1911A1 semi-automatic pistol. Designed by John Moses Browning, the 1911A1 is a standard single-column magazine-fed pistol while the 1911A2 is double column.

SPECIFICATIONS

Model	1911A1 / 1911A2
Caliber	45 ACP / 9MM / .38 Super / .40S&W
Action	Semi-Automatic, Recoil Operated
Magazine capacity	8 rounds / 13 rounds - Cal. 45 9 rounds / 17 rounds - Cal. 9MM / .38 Super 15 rounds - Cal. 40 S & W
Overall length	222 mm
Overall width	33 mm / 40 mm
Overall height	140 mm
Weight (empty)	1.11 kg / 1.14 kg
Weight (loaded)	1.29 kg / 1.43 kg
Barrel length	127 mm / 5"
Trigger pull	1.81 to 2.95 kg. Ave.
Sights	Fixed front and rear
Rifling	Right hand twist, one turn in 400 mm
No. of grooves	6
Finish	Blued or Parkerized

SAFETY INSTRUCTIONS

Firearms can cause serious injury and death. Always think of firearms as dangerous weapons and it is your responsibility to handle guns safely.

Always treat gun as though it were loaded.

Always keep the muzzle pointed in a safe direction.

Even if there are safety features incorporated in your firearm, do not rely on these mechanical features alone.

Safe gun handling is your responsibility. Accidents happen when you violate the basic rules of safe gun handling and common sense.

BASIC RULES IN HANDLING A FIREARM

1. Never point the gun at anyone or anything you don't intend to shoot.
2. Understand fully the operation of the firearm before handling it.
3. Always keep your gun pointed in a safe direction.
4. Treat every firearm as if it were loaded.
5. Do not insert your index finger in the trigger guard unless you are ready to shoot.
6. Always check the gun for live ammunition when you pick it up (with index finger outside the trigger guard), hand to or receive from another person.
7. If you must carry a loaded firearm, always make sure the muzzle is pointed in a safe direction.
8. Do not load and cock your firearm unless you are ready to shoot.
9. Be sure of your target and what is beyond that target in case you miss.

10. As safety precaution, wear eye and ear protectors when shooting indoors or out.
11. Make sure you have a safe backstop behind your target to avoid dangerous ricochets.
12. Do not shoot directly at a hard surface or at water.
13. Do not use or experiment with unfamiliar ammo that have pressure levels exceeding industry standards. Untested loads can damage your firearm and cause injury to you and bystanders.
14. If your gun fails to fire when the hammer falls, keep the gun pointed in a safe direction, remove your finger from the trigger and outside the trigger guard away from the ejection port, wait 10 seconds before inspecting it.
15. Do not drink alcoholic beverages or take prohibited drugs when handling a firearm.
16. Never leave a pistol cocked and ready to fire.
17. Think before you shoot.

SAFETY FEATURES

1. TRIGGER GUARD - this is the metal loop around the trigger to protect it from damage and to help prevent accidental discharge.
2. SLIDE LOCK SAFETY - also known as thumb safety lock because the thumb is used to apply or disengage this safety which can happen when the hammer is fully cocked. When up and engaged, it blocks the sear and hammer so the gun cannot fire. This safety also prevents rearward movement of the slide.
3. GRIP SAFETY - this safety prevents rearward travel of the trigger. The gun can only be fired if the grip safety is firmly pressed in when grasped by the hand to then allow trigger movement.
4. DISCONNECTOR SAFETY - this safety device prevents a round from being fired before it is in the chamber with slide and barrel locked. The disconnecter enables the pistol to fire only when fully locked and trigger is released.
5. HALF-COCKED POSITION - the half-cocked notch in the hammer allows it to be locked in a half-cocked position. This happens in situations of unintentional hammer release or follow through caused by sear bounce.
6. INERTIA FIRING PIN - the firing pin, designed to be shorter than its housing, is held to the rear by a spring and can only protrude to hit a cartridge primer when a fully cocked hammer blow overcomes the spring force and the inertia of the spring.

AMMUNITION

This firearm is chambered for cartridge in the round nose configuration (Note: Use of wadcutter may require extra adjustment of the barrel feed ramp by a competent gunsmith). Use factory loaded cartridges manufactured in accordance with industry standards. Always examine your ammo particularly on and around the primer before loading the magazine.

Look for dents, scratches, improper crimping, loose case mouths, and other signs of damage.

LOADING

Do not load live ammunition into your firearm until you are ready to use it. Keep the muzzle pointing in a safe direction, well clear of your body when loading and unloading.

LOADING THE MAGAZINE: Grasp magazine in one hand and place a round on the magazine follower with the base of shell first and push down. Let the cartridge slide under the feed lips until base of cartridge touches the flat edge of the magazine. Place next round on top of previous round, press down again and into back. Repeat until the magazine is loaded to its rated capacity. Do not exceed capacity.

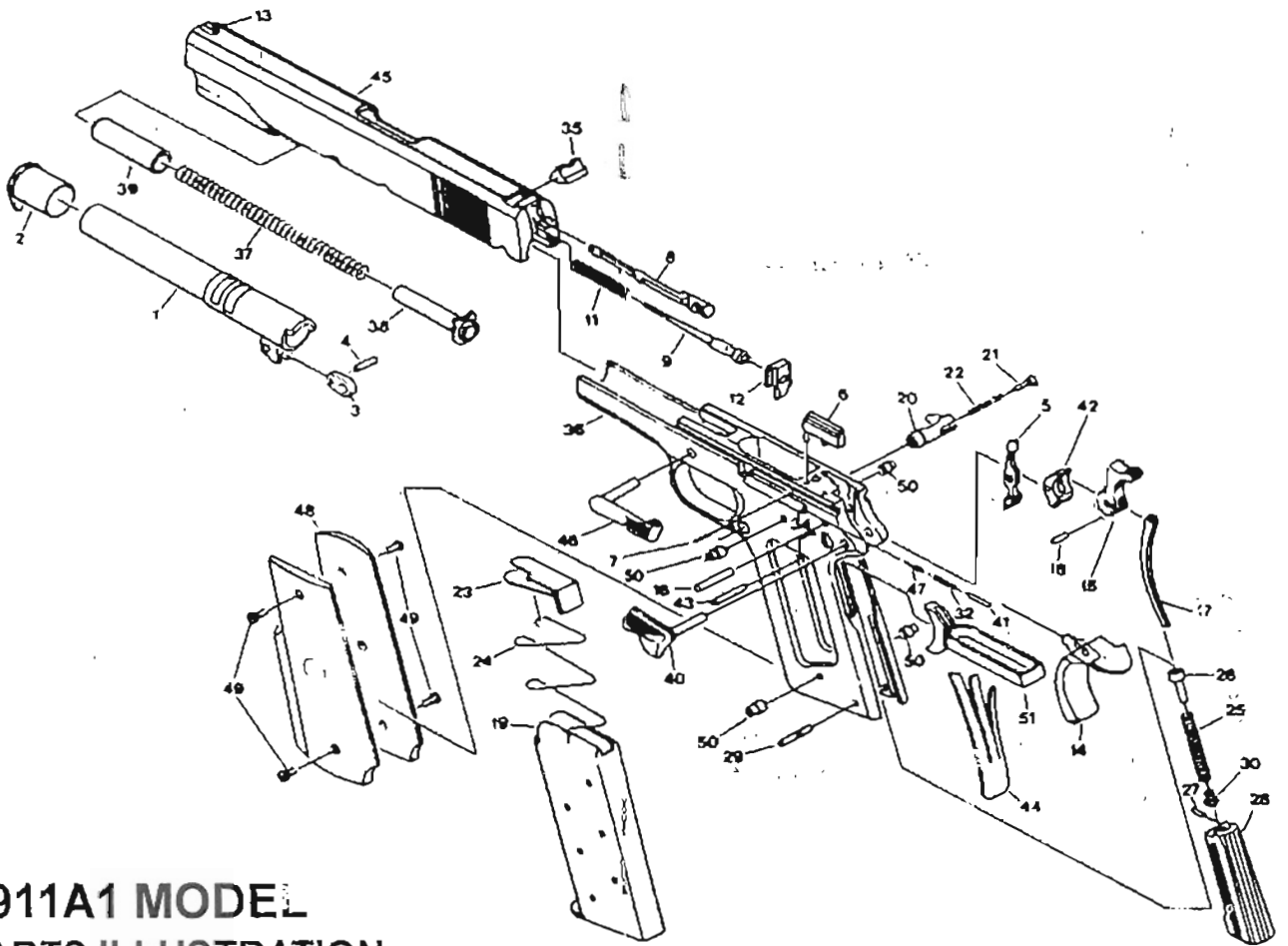

**1911A1 MODEL
PARTS ILLUSTRATION**

LOADING THE PISTOL

Keep pistol pointed in a safe direction and keep your index finger outside the trigger guard when doing this procedure.

When pistol is clear and empty of shells or cartridges, insert the loaded magazine into the magazine well with bullets pointing forward. Push the magazine firmly home until magazine catch is heard to click ensuring it is locked in place.

When you are ready to shoot, grip and pull the slide at its serrated finger grips rearward to fully cock the hammer. Releasing the slide effects the feeding of the first cartridge of the magazine into the chamber.

YOU ARE NOW LOADED, COCKED AND READY TO FIRE.

Push up the safety lock with your thumb into the SAFE position.

When you are ready to shoot, push the safety lock down with your thumb into the FIRE position, make sure your target is in your sights, put your index finger on the trigger and squeeze the trigger. Do not pull on the trigger as this cause your aim to go bad with the unnecessary jerking motion.

After the first round is fired, ease off on your finger on the trigger to release it making it ready for you to fire the next round. Repeating this sequence will eventually empty the magazine and when that happens, the slide will remain at the rear of the frame with the slide stop holding it back at the rear.

Keep in mind that the pistol is still loaded and point the muzzle in a safe direction and take your finger off the trigger and outside the trigger guard.

UNLOADING THE FIREARM

Place your free hand under the magazine to prevent it from falling and press magazine catch to release and eject the magazine. Check the chamber for an unejected shell or unfired cartridge and remove such from the chamber. Press the slide stop down to allow it to move forward to its normal position. The pistol is now unloaded.

MAINTENANCE

Keeping your firearm clean and properly lubricated will extend its serviceable life. Proper and efficient functioning depends on how you take care of the precision mechanisms of your firearm.

PARTS LIST

- | | | |
|-----------------------|--------------------------------------|-------------------------|
| 1. Barrel | * 19. Magazine Box | 37. Recoil Spring |
| 2. Barrel Bushing | * 20. Magazine Catch | 38. Recoil Spring Guide |
| 3. Barrel Link | 21. Magazine Catch Lock | 39. Recoil Spring Plug |
| 4. Barrel Link Pin | 22. Magazine Catch Spring | 40. Safety Lock |
| 5. Disconnecter | * 23. Magazine Follower | 41. Safety Lock Plunger |
| 6. Ejector | * 24. Magazine Spring | 42. Sear |
| 7. Ejector Pin | 25. Main Spring | 43. Sear Pin |
| 8. Extractor | 26. Main Spring Cap | 44. Sear Spring |
| 9. Firing Pin | 27. Main Spring Cap Pin | 45. Slide |
| 11. Firing Pin Spring | 28. Main Spring Housing | 46. Slide Stop |
| 12. Firing Pin Stop | 29. Main Spring Housing Pin | 47. Slide Stop Plunger |
| 13. Front Sight | 30. Main Spring Housing Pin Retainer | * 48. Grip Set |
| 14. Grip Safety | 32. Plunger Spring | * 49. Grip Screws |
| 15. Hammer | 34. Plunger Tube | 50. Grip Screw Bushing |
| 16. Hammer Pin | 35. Rear Sight | * 51. Trigger Assembly |
| 17. Hammer Strut | 36. Frame | |
| 18. Hammer Strut Pin | | |

- Notes: 1. Parts marked with asterisk should be specified if 1911A1 or 1911A2
2. Specifications subject to change without prior notice

FIELD STRIPPING : DISASSEMBLY

1. Press the magazine release and remove the magazine. Pull the slide back and check the chamber to ensure that the pistol is unloaded and safe to handle.
2. Press the recoil spring plug with your thumb and rotate the barrel bushing clockwise.
3. Slowly allow the plug and recoil spring assembly to move forward. Do not remove yet as this will keep the recoil spring guide in place.
4. Pull slide back until the lug on the slide stop is opposite the disassembly notch and push rounded end of pin of slide stop found at right side of frame. Push inward and through the frame to disengage slide stop from slide and frame.
5. Pull the slide forward on its guide rails in the frame. The barrel, barrel bushing, recoil spring, recoil spring guide and recoil spring plug will come out with it.
6. Remove the recoil spring guide and plug from the slide.
7. Rotate the barrel bushing to the left as far as it will go and pull it out to the front.
8. Tilt the barrel link forward to remove the barrel through the front of the slide.
9. Remove the firing pin by pressing it with a pin while pushing the firing pin stop downwards at the same time and out of the slide.
10. Pry the extractor with a pin by its groove out of the slide.

FRAME DISASSEMBLY

1. Remove the grip panels by unscrewing the grip screws with a properly sized screwdriver to avoid damage on screwheads.
2. Cock the hammer. Hold the thumbpiece of the safety lock firmly and pull it out slowly by twisting it back and forth until it is out of the frame.
3. Carefully lower the hammer by grasping the grip safety and squeezing the trigger while holding on to hammer to ease it down.
4. Using the pivot stud of the safety lock, force the hammer pin out of the frame. The hammer and the hammer strut attached to it can now be removed.
5. Use the end of the hammer strut to push the mainspring housing pin out of the right side of the frame.
6. Remove the mainspring housing assembly down off its grooves in the frame.
7. Remove the grip safety and sear spring rearward from the frame.
8. Use the hammer strut again to push the sear pin from right to left removing it out of the frame. The sear and disconnect, both mounted on the sear pin can now be removed from the frame.
9. Push the magazine release partially and rotate the magazine release lock one quarter turn from right to left with properly sized screw driver to remove the magazine release assembly from the frame.
10. Remove the trigger assembly from its recess cuts in the frame.
11. Push the combination slide and safety lock plungers and the spring between them out to the rear of the plunger tube.
12. The mainspring housing assembly is dismantled by forcing the main spring down with a punch and push the main spring cap pin out of its hole in the mainspring housing. The main spring cap, main spring housing pin retainer can now be removed from the housing.

REASSEMBLY

To reassemble the pistol the reverse procedure of disassembly is usually followed.

Please be guided by the additional instructions for proper assembly.

1. Mount the barrel and slide assembly on to the frame by holding both slide and frame bottom side up. Barrel link must be tilted to the front as far as it can go and make sure the barrel link pin is flush in its seat. You can now slide the frame forward into the slide rails.
2. Disconnect and sear are to be assembled together and must be in the proper position. This can be done by first mounting the sear over the disconnecter with the curved section inward and lugs pointing downward. Mount the parts together into the frame by inserting the rounded head of the disconnecter in its hole in the frame so that the flat face of its lower end rests against the trigger stirrup. Partially press the trigger so the holes of the two parts will line up with that of the frame. Holding them this way, insert the sear pin from the left side of the frame making sure it passes through both disconnecter and sear.
3. When placing back the sear spring, make sure that the lower end is caught in the slot located at the bottom of the frame handle. The upper end of the left-hand leaf must rest against the sear. While retaining this position, slide the mainspring housing up in its grooves until its end is projecting only about one-eighth of an inch below the edge of the bottom of the frame.
4. Cock the hammer to replace the safety lock.
5. After replacing the hammer, grip safety and safety lock, cock the hammer. Make sure the hammer strut rests on the main spring cap. Then, push the mainspring housing up into the frame to its final position and retain the assembly by driving in the mainspring housing pin.

BASIC MAINTENANCE OF YOUR FIREARM

Clean your firearm after firing:

Remove the barrel and slide assembly from frame.

Use a bore brush dipped in a gun cleaning solvent to scrub barrel bore and chamber and remove all lead residue.

Clean the slide's breech face area. Use an old toothbrush with solvent to remove residue from powder and primers.

Also clean the insides of the slide and barrel locking lugs, frame and slide rails, extractor & firing pin.

After brushing, clean up with a clean dry cloth and wipe all parts and surfaces clean of solvent. Immediately apply some gun oil to preserve and lubricate the moving parts.

If you are going to store your firearm for an indefinite period of time, apply a thicker film of oil with a lubricant that is acid-free.

Coat the external parts and surfaces with anti-rust oil or gun grease to prevent rusting. To use firearm again from this condition, clean thoroughly and wipe dry again. Check all functions before loading. Moisture and humidity are factors that cause rust and corrosion.

Store your firearm in very dry conditions with very low humidity. Avoid leather as this holds moisture. Oil coated plastic bags are better.



ROCK ISLAND ARMORY PISTOLS

are assembled by:

TWIN PINES, INC.

Manila, Philippines