



NHM-91

SEMI-AUTOMATIC RIFLE

INSTRUCTION MANUAL



A free copy of this instruction manual for the NHM91 model of sports firearm is available from C.S.I. on request. This instruction manual contains important warnings which should be read and understood before using firearms. This instruction manual should always accompany this firearm and be transferred with it upon change of ownership.

ChinaSports Inc
P.O. BOX 3250 • ONTARIO, CA 91761

CONSTRUCTION

Solid steel construction is used throughout for the operating components, with the exception of the stocks, which are either wood or high strength, heat resistant synthetic material.

PRINCIPLES OF OPERATION

Your ChinaSports NHM-91 is a semi-automatic or self-loading, magazine-fed repeating rifle. Gas pressure generated by the fired cartridge is utilized to drive the rifle's gas piston system to automatically eject the case, recock the hammer/trigger mechanism, and load a fresh round from the magazine to the barrel chamber. A single shot will be fired with each pull of the trigger, until both magazine and chamber are empty. The trigger must be fully released forward before it can be pulled again to fire a succeeding shot.

WARNING

Before firing this rifle, be absolutely certain there are **NO OBSTRUCTIONS** in the barrel bore and chamber, such as grease, mud, snow or cleaning patches, etc. also check your ammunition to determine it is in good condition and that it is the correct caliber and specific type of commercial manufacture intended for this gun. The proper caliber description (stamped on the left receiver wall of the rifle) is 7.62x39mm or .223 centerfire. Be sure rifle is assembled correctly.

OPERATING THE SAFETY

This rifle is equipped with a manually operated safety device in the form of a long pivoted lever located on the right hand side of the receiver. When set in the upper "safe" position, a letter S on the receiver is visible just forward of the tip of the lever. In this safety position the trigger is blocked from being pulled to release the hammer and fire the rifle. In addition, being on "safe" serves two other functions: it prevents foreign matter from entering the mechanism through the bolt handle slot in the receiver cover, and also prevents the handle from being pulled far enough to the rear to pick up and feed around from a loaded magazine into the empty barrel chamber.

To set to "fire" position, the lever must be pushed downward with the thumb until it clicks to a stop. Again, a letter F indicating that the safety is in "fire" mode will be visible just forward of the lever tip. The trigger may now be pulled to fire the rifle as described previously.

CAUTION

Unless you are actually firing or plan to do so immediately, **THE SAFETY LEVER SHOULD BE KEPT IN "ON SAFE" POSITION** regardless of whether the rifle is loaded or unloaded.

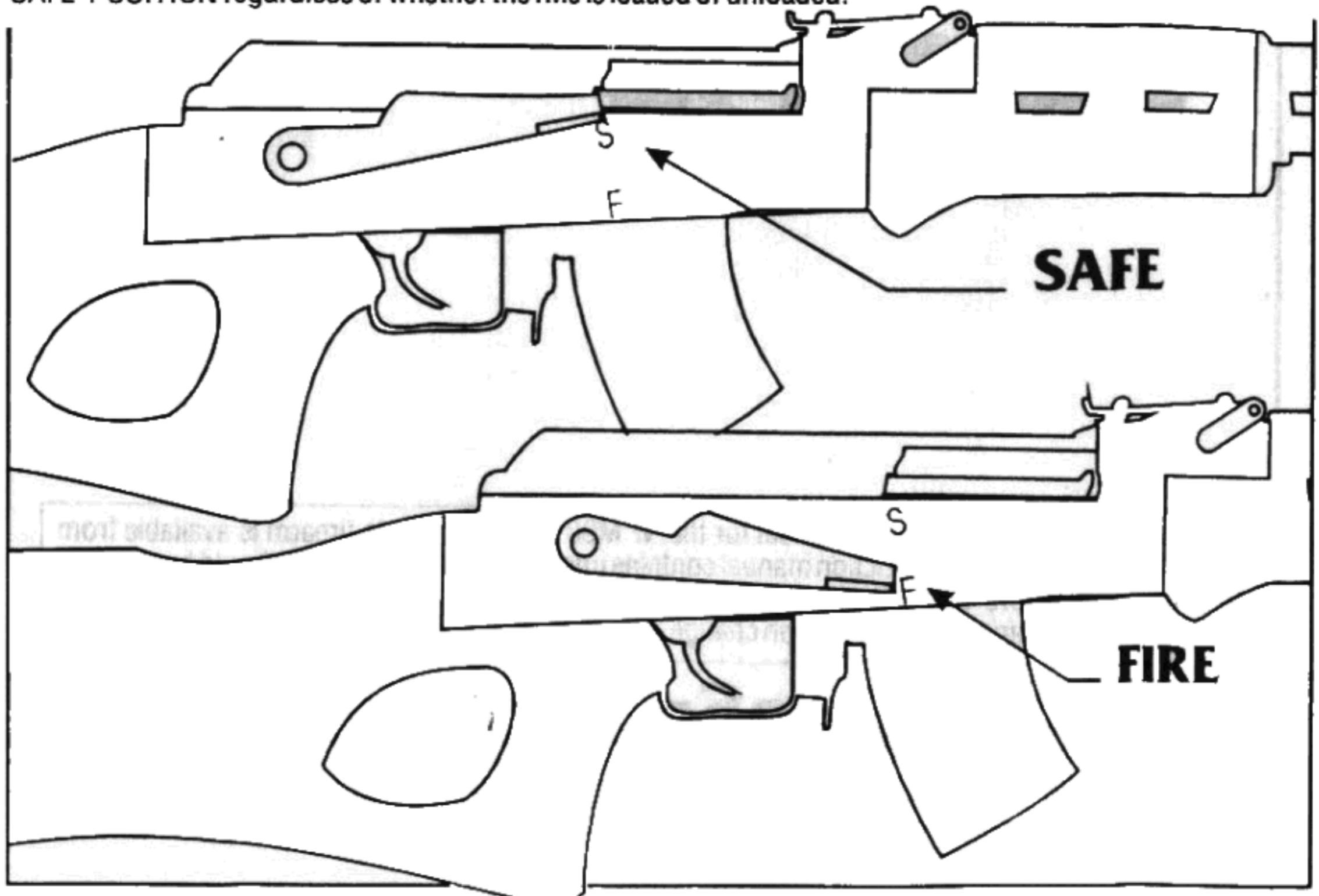

LOADING THE MAGAZINE

Your NHM91 is fed by a detachable steel box magazine with a maximum capacity of 5 cartridges or rounds.

To charge or fill the magazine, hold it in either hand with the top of the magazine lips visible above the top of your hand. Place a cartridge full length between the two lips (bullet end to the front of the magazine) and press down firmly with the thumb until the round snaps into place and is held within the magazine beneath the feed/retaining lips. Take care to be sure that the bullet tip does not protrude beyond the front end of the magazine when inserting it. Repeat this process for the desired number of rounds or until the magazine has reached maximum capacity.

LOADING THE RIFLE

When inserting a loaded magazine in the rifle, you must **ALWAYS** observe these safety precautions:

Be sure the rifle muzzle is pointed forward and down towards the ground in a **SAFE** direction ahead of you.

Push the safety lever to the upper "on safe" position.

Grasp the rifle by the forearm with either hand. With the other hand, hold the magazine toward the bottom with the feed lips in above the top of the hand. Now insert the magazine into the well or port in the bottom of the receiver forward of the trigger guard, top front corner first to engage the magazine forward retaining bar, and then push backward and up until the magazine catch locks the magazine in place.

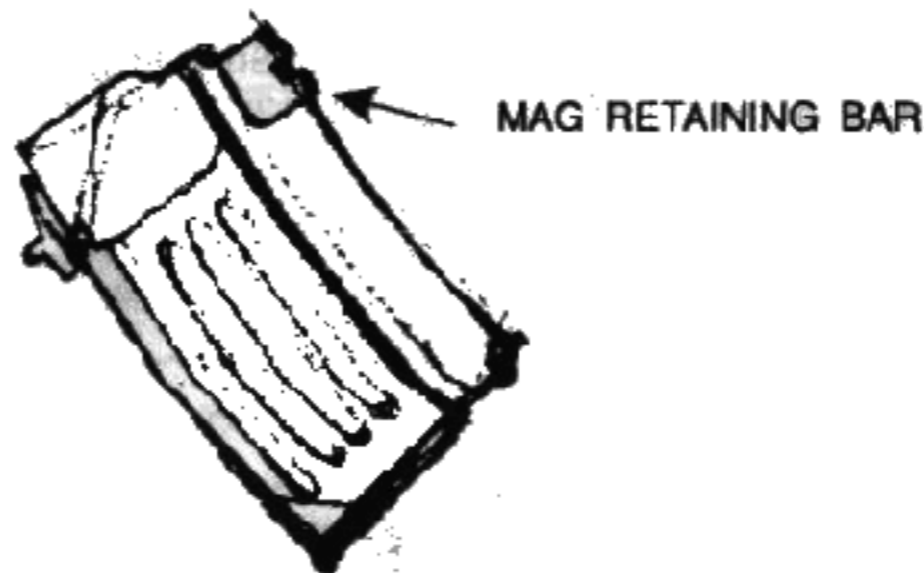

CHAMBERING A ROUND AND FIRING

To fire the rifle, a round must first be introduced from the magazine to the barrel chamber. With a loaded magazine in place and muzzle pointed in a **SAFE** direction, push the safety lever down to the "fire" position. Hold the rifle forearm firmly with the off hand and grasp the bolt handle with the firing hand. Pull the handle smartly, fully to the rear until it stops and then completely release it, allowing it to spring forward and chamber a round.

WARNING

At this point the rifle is fully loaded and armed, with the safety off to "fire" position. A **PULL ON THE TRIGGER WILL FIRE AND INSTANTLY RELOAD THE GUN**. If you do not intend to fire immediately, place the safety lever to "safe" position.

UNLOADING THE RIFLE

With the rifle pointed in a safe direction, the magazine is gripped by the firing hand with the thumb placed behind the magazine release lever. While pressing this lever forward, simultaneously sweep the magazine body forward and down to remove the magazine from the rifle receiver. Still holding the rifle by the forearm, push the safety lever to the lower or "fire" position. Grip the bolt handle and pull it fully to the rear to extract and eject any unfired round that may remain in the barrel chamber. Hold the handle to the rear and visually inspect both barrel chamber and bolt face to confirm the unloaded status. Release the bolt handle and, while pointed in a safe direction, pull the trigger to drop the hammer on an empty chamber. Now, push the safety lever to "on safe" position.

To unload the magazine, push forward with the thumb on the base of each cartridge (opposite bullet end) until it is released by the feed lips.

DISASSEMBLY

CAUTION: Check to be certain the rifle is FULLY UNLOADED as described previously and safety is set to "safe" position.

Hold the buttstock firmly in one hand. With the thumb of the other hand, push the end of the recoil guide and spring unit projecting from the rear of the receiver cover fully forward and lift the receiver cover upward and back from its rearend.

With the receiver cover off, grip the end of the recoil guide and spring unit, and push it forward until it clears its grooved seat in the receiver. Lift it up slightly and pull it straight back to remove the unit from the bolt carrier/gas piston unit.

Place the safety to the "fire" position. Grasp the bolt handle and draw it back firmly to the full rear of its travel. Lift the bolt carrier/gas piston unit slightly from the receiver and draw it to the rear and out of the gas tube and handguard assembly.

To remove the bolt from the bolt carrier, push the bolt to its rear position in the carrier and rotate it a quarter turn clockwise (right). Then push the bolt forward and out of its bore in the carrier.

The gas tube and handguard assembly may be removed by rotating the gas tube latch lever up (with the provided disassembly tool) and pulling rear of handguard up and back until the assembly is free.

This completes what is commonly known as "field stripping." No further disassembly is recommended except by a qualified gunsmith or C.S.I.'s service department.

REASSEMBLY

Reassembly follows in the exact reverse sequence of disassembly steps. To insure trouble-free reassembly, we recommend that you pay close attention to the exact location and position of parts during disassembly so that you can duplicate their attitude during reassembly.

CLEANING

With the rifle in "field stripped" condition:

Using a suitable cleaning rod and brush, saturate the brush with a commercial gun solvent and run the brush from the muzzle end through the length of the bore and out the chamber end several times. Follow this same procedure but substitute solvent-soaked cloth cleaning patches for the brush. When the bore and chamber are clean, run dry cloth patches through to remove the solvent film.

If you do not intend to fire the rifle soon, run a patch with a small amount of gun oil through the bore to preserve it.

The stripped action parts should be wiped clean of any fouling with solvent and dried. These parts should then receive a LIGHT film of gun oil to protect and lubricate them. The gas piston and gas tube, however, SHOULD NOT BE OILED, just cleaned and dried.

All exterior metal surfaces should be periodically wiped clean and lightly oiled.

RECEIVER COVER

PUSH

UNLOADED & "SAFE"

BOLT CARRIER & GAS PISTON
RECOIL GUIDE & SPRING

GAS TUBE LATCH LEVER

GAS TUBE / HANDGUARD ASSY.

BOLT CARRIER / GAS PISTON UNIT

"FIRE" POSITION

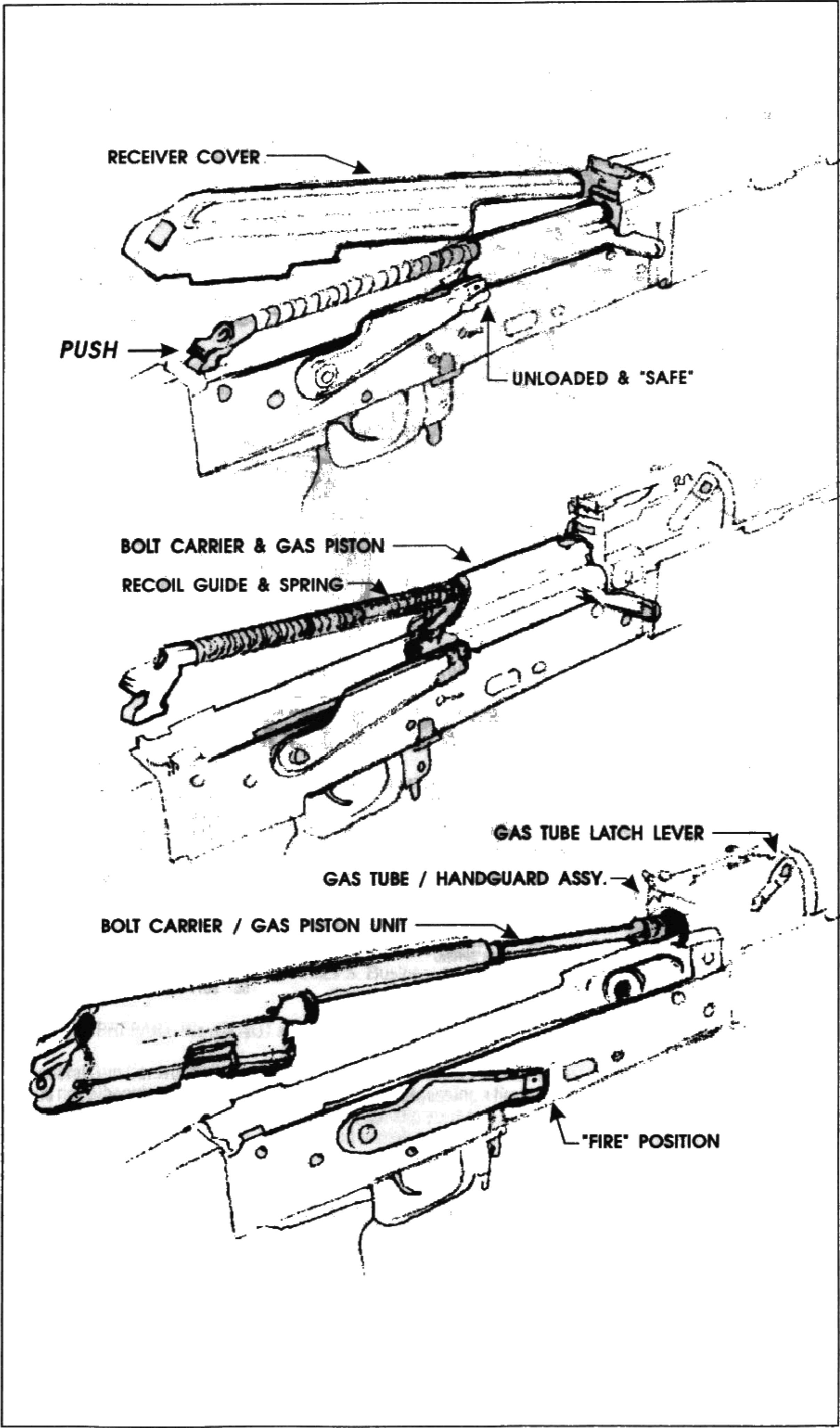

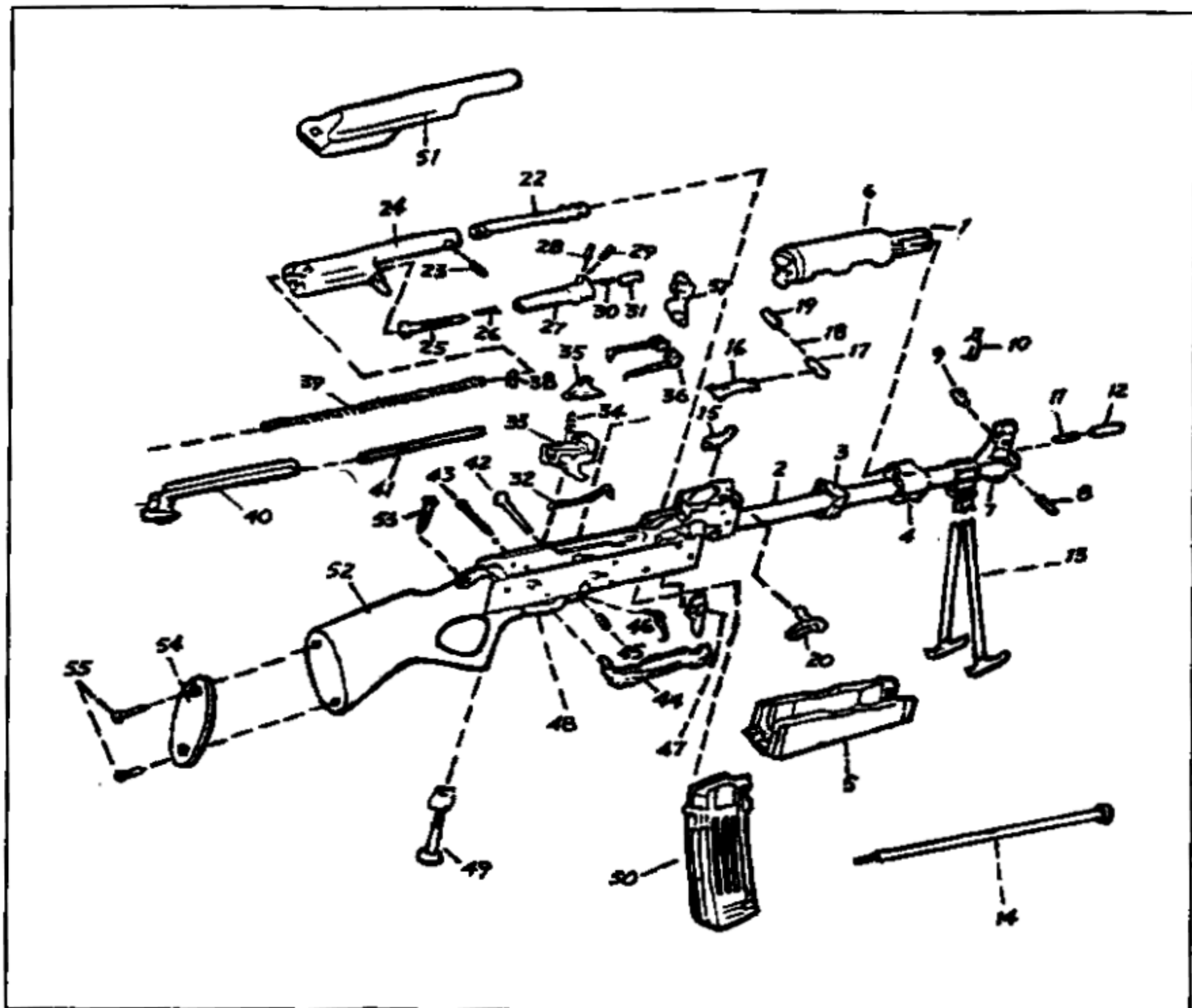

PARTS LIST

- | | | |
|---------------------------------------|-----------------------------------|------------------------------|
| 1. GAS TUBE | 22. GAS PISTON | 41. FRONT SPRING GUIDE |
| 2. BARREL | 23. GAS PISTON RETAINING PIN | 42. HAMMER PIN |
| 3. FOREARM CAP | 24. BOLT CARRIER | 43. TRIGGER PIN |
| 4. GAS CONNECTOR | 25. FIRING PIN | 44. SAFETY LEVEL |
| 5. FOREARM | 26. FIRING PIN SPRING | 45. MAGAZINE CATCH PIN |
| 6. UPPER HAND GUARD | 27. BOLT | 46. MAGAZINE CATCH SPRING |
| 7. FRONT SIGHT ASSEMBLY | 28. FIRING PIN RETAINING PIN | 47. MAGAZINE CATCH |
| 8. FRONT SIGHT BASE PIN | 29. EXTRACTOR PLUNGER | 48. RECEIVER & TRIGGER GUARD |
| 9. FRONT SIGHT ADJUSTMENT BLOCK | 30. EXTRACTOR SPRING | 49. GRIP SCREW & NUT |
| 10. FRONT SIGHT POST | 31. EXTRACTOR | 50. MAGAZINE |
| 11. MUZZLE CAP PIN SPRING | 32. HAMMER & TRIGGER PIN RETAINER | 51. RECEIVER COVER |
| 12. MUZZLE CAP PIN | 33. TRIGGER | 52. BUTT STOCK |
| 13. BI-POD | 34. SEAR SPRING | 53. BUTT SCREW |
| 14. CLEANING ROD | 35. SEAR | 54. RECEIVER |
| 15. REAR SIGHT SPRING | 36. HAMMER SPRING | 55. BUTT PLATE |
| 16. REAR SIGHT | 37. HAMMER | |
| 17. REAR SIGHT ADJUSTING BLOCK | 38. FRONT GUARD RETAINER | |
| 18. REAR SIGHT ADJUSTING SLIDE SPRING | 39. RECOIL SPRING | |
| 19. REAR SIGHT ADJUSTING SLIDE INSERT | 40. REAR SPRING GUIDE | |
| 20. GAS TUBE LATCH LEVEL | | |

ACCESSORIES

The "L" shaped tool included in the box is the gas tube cleaning tool.

SERVICE POLICY

NOTICE: All requests and correspondence regarding service, repair, or parts must be sent directly to C.S.I., NOT your store of purchase. No gun returns will be accepted without our prior written approval.

All guns have been carefully inspected and test fired to insure that they fully conform to our quality and safety standards.

- 1.** All orders for replacement of damaged parts must be handled under the instructions for ordering parts.
- 2.** We will accept a gun for repair or service only if in original, unaltered purchase condition and if we consider that it is defective in either materials or workmanship; the gun will be returned prepaid in this event.
- 3.** Repairs or service to guns that, in our opinion, have suffered from user abuse, neglect or unauthorized alteration, will be done at our quoted parts and service charge. The gun may be returned to us prepaid for inspection only. You will be advised by return mail of service charges required. No work will commence until after your written approval and payment of our quoted charge. Guns will be returned collect in this event.
- 4.** Please enclose a letter with returned guns, stating the nature of the trouble experienced, or work desired. Also enclose copies of any previous correspondence.
- 5.** All remittances must be made by money order or certified check.

Any unauthorized conversion or alteration to our goods will automatically null and void any obligation, expressed or implied, in our service policy statement.

Please note that prices are subject to change at our discretion without notice.

SHIPPING FIREARMS

All modern firearms returned to the C.S.I. service department should be sent to:

ChinaSports Inc.
Attn: Service Dept.
2010 S. Lynx Pl.
Ontario, CA 91761

Ship the gun PREPAID. We will NOT accept collect shipments.

The Federal Gun Control Act, as well as the law of most States and localities, does not prohibit an individual (who is not otherwise barred from purchasing or possessing a firearm) from shipping a firearm directly to the manufacturer for repair. However, before you ship your gun to us, be certain that your State or locality does not have a law or regulation which would prohibit you from receiving the gun from us after it has been repaired. If such a law or regulation prohibits you, then please have a Federal Firearms Licensed dealer ship the gun to us. It will be returned to him after being repaired.

Rifles and shotguns may be shipped by Parcel Post or via UPS. Always properly insure the shipment.

An individual may NOT ship a handgun by U.S. Mail.

IMPORTANT NOTICE

Please DO NOT RETURN LOADED GUNS. Federal regulations prohibit shipment of loaded guns. If guns are sent to us in this condition, we must notify Federal authorities. Therefore, you must have a qualified person unload any gun in this condition (i.e. jammed) before returning.

SAFETY RULES

- 1. Never climb a tree, or fence, or wall while carrying a loaded gun.**
- 2. Never let a gun rest against a tree or fence or wall. If you are going to leave a gun, make sure it is unloaded and lying flat or secured in a proper rack or holding device.**
- 3. Don't "horseplay" with a gun. Your gun can't think -- but you can. Firearms safety depends on you.**
- 4. Never point a gun at any person or any object that you don't intend to shoot.**
- 5. Never accept a gun without opening it to check for yourself whether or not it is loaded.**
- 6. Always load guns with muzzle pointing at the ground.**
- 7. Always unload guns with muzzle pointing at the ground.**
- 8. Reloaded cartridges can be dangerous to you and to your gun.**
- 9. Never leave a gun unattended.**
- 10. Store guns and ammunition separately and BEYOND THE REACH OF CHILDREN.**
- 11. Never take alcohol, drugs, or medications immediately before or during shooting activities.**
- 12. Never shoot at flat hard surfaces or at the surface of water.**
- 13. Check ammunition to see if it is the right size. Old ammunition is not safe to use.**
- 14. Should a gun fail to discharge after trigger has been pulled, keep gun pointing at target for at least 30 seconds. Sometimes a slow-burning primer will not ignite promptly and properly and will cause a "hang fire."**
- 15. Get instructions from a competent firearms instructor before using any gun.**
- 16. Write to us concerning any items or circumstances which you don't understand and which might relate to your safety and the operation of any of our products.**
- 17. Wear fluorescent orange vest, hat, and jacket when in the woods or fields.**
- 18. Spectators should always be at least 10 feet in back of and not in line with the breech of any gun when you are shooting.**
- 19. Never put your hand over the muzzle of a gun.**
- 20. Alterations of trigger pull will usually alter sear engagement and can cause accidental discharge.**
- 21. Never take a gun out of a car, boat, or RV by pulling it toward you by the muzzle.**
- 22. Never leave a gun where it could fall and accidentally discharge.**
- 23. Never pull the trigger unless shooting at a target, or unless you have checked to make sure that the gun was unloaded.**
- 24. Never assume that a gun is unloaded.**
- 25. Never have a loaded gun in a house, car, boat, RV, truck, etc.**
- 26. Always empty guns before carrying into house, car, boat, RV, truck, etc.**
- 27. Always wear protective shooting glasses and ear protection when shooting on the range or in a field, forest, or boat.**
- 28. Use only standard loads from reputable manufacturers.**
- 29. Always load your gun only when on the range or in the field and ready to shoot. When you stop shooting, unload before leaving the range or field.**
- 30. Always keep your finger off the trigger until you are ready to shoot.**
- 31. Never rely on a gun's "safety" to compensate for unsafe gun handling. A safety is only a mechanical device, not a substitute for good common sense.**
- 32. Never leave a loaded gun lying on the ground or propped against a rock, or tree, or car, or any object.**
- 33. Be sure of your backstop and what lies beyond before you shoot.**