

CROSMAN® / SKANAHER

MODEL 88 - OWNER'S MANUAL



CROSMAN AIRGUNS  
**Challenger**®

## CONGRATULATIONS

You have just purchased the first CO<sub>2</sub> competition air pistol produced by an American manufacturer.

The Crosman®/Skanaker Model 88 Pistol is the culmination of years of work, on both sides of the Atlantic. We have combined the hands-on experience of the world's top pistol shooter, Ragnar Skanaker, with the skills of Crosman's finest design engineers. The result is a single shot competition grade air pistol that is clearly unique.

Perhaps the greatest innovation is its patented fully adjustable pistol grip. The entire grip can be canted upwards or downwards to perfectly suit your line of sight. It truly becomes an extension of the arm. Adjustments for height and thickness enable you to precisely fit the 88 to your hand.

The mechanical trigger is also unusual in the way it is fitted. It's angled to adapt ideally to the natural position of the index finger while shooting and can be adjusted in any direction.

The pivoting barrel is hinged near the muzzle to tip upward for easy pellet loading directly into the barrel. (Patents Pending)

Please take the time to read this manual thoroughly. It will explain how to properly adjust and safely operate your Crosman®/Skanaker Model 88.

**CAUTION:** THIS AIRGUN IS DESIGNED FOR USE BY EXPERIENCED SHOOTERS AND IS INTENDED FOR MATCH COMPETITION OR TARGET RANGE USE. CARELESS USE MAY RESULT IN SERIOUS INJURY OR DEATH. DANGEROUS WITHIN 475 YARDS (435 METERS). THIS AIRGUN IS NOT EQUIPPED WITH A TRIGGER SAFETY. IT MAY HAVE A TRIGGER PULL BELOW TWO (2) POUNDS AND MAY FIRE WHEN DROPPED. BUYER AND USER HAVE THE DUTY TO OBEY ALL LAWS ABOUT THE USE AND OWNERSHIP OF THIS AIRGUN.

## TABLE OF CONTENTS

	PAGE
Important Safety Rules .....	3
General Directions for Use .....	4
Filling CO <sub>2</sub> Tube .....	5-6
Inserting Refill Tube .....	7
Cocking, Loading and Unloading .....	7-8
Adjusting Grip .....	9-10
Trigger Adjustments .....	11-12
Sight Adjustments .....	13-14
Trouble Shooting .....	15-16
Specifications .....	17
Warranty .....	18

### IMPORTANT SAFETY RULES

- This pistol is for use by experienced adult shooters. Never allow an inexperienced person, especially youth, to use the airgun without proper supervision!
- Don't point at anything you don't intend to shoot. Always aim in a SAFE DIRECTION.
- Always handle your pistol as though it were loaded.
- Don't put the pistol away loaded. Make sure the pistol is unloaded and the CO<sub>2</sub> tube removed.
- Do not attempt to disassemble or tamper with your pistol. Return the airgun to Crosman Airguns for repair.
- Be sure you have a safe backstop and target. Stop using a backstop if it becomes worn and be sure to place the backstop in a location that will be safe should the backstop fail.
- Don't shoot at hard surfaces or at the surface of water. The pellet may ricochet.
- Keep hands away from escaping CO<sub>2</sub> gas. It can cause frostbite if allowed to come in contact with skin. To prevent injury, wear eye and hand protection.
- When making any adjustments to the pistol, make sure it is unloaded and the CO<sub>2</sub> tube is removed.

3

### GENERAL DIRECTIONS FOR USE

Do not store your pistol with a charged CO<sub>2</sub> tube on it. In addition to this being an unsafe practice, it also will cause unnecessary wear on the seals. The refill tube can be removed from the gun by simply turning it counterclockwise.

When making adjustments to the pistol, always make them in small increments. The adjustment mechanisms are very sensitive. Never overtighten the screws. You may strip them which would require that the pistol be returned to Crosman for service.

This pistol does not come equipped with a switch which allows you to dry fire it without expelling gas. If it becomes necessary for you to dry fire the pistol during competition, you may do so by unscrewing the gas tube until you hear the gas escape from the valve. You can then dry fire as many shots as you wish. When preparing to resume firing, merely screw the tube back in. This procedure will only cost you the loss of gas for one shot.

In order to manufacture the Model 88 to be as light and durable as possible, it was necessary to make the pistol frame out of magnesium. Magnesium being a very light metal cannot withstand the pressure exerted upon it by a steel vice. Therefore, **DO NOT VICE THIS PISTOL.** It has been tested for accuracy at the factory prior to shipment.

**CAUTION: BEFORE MAKING ANY TYPE OF ADJUSTMENTS TO YOUR PISTOL, MAKE SURE IT IS NOT LOADED AND REMOVE THE CO<sub>2</sub> CYLINDER SO THERE WILL BE NO DANGER OF ACCIDENTAL DISCHARGE.**

4

## FILLING CO<sub>2</sub> TUBE

**NOTE:** *Must* use CO<sub>2</sub> source that has a syphon tube to ensure filling with liquid. Tanks without syphon tubes must be tilted downward at an angle of at least 30 degrees.

**CAUTION:** KEEP HANDS AWAY FROM ESCAPING CO<sub>2</sub> GAS. IT CAN CAUSE FROSTBITE IF ALLOWED TO COME IN CONTACT WITH SKIN. TO PREVENT INJURY, WEAR EYE AND HAND PROTECTION.

1. It is advisable to wrap the threads on the tank and the bottom of the refill tube with Teflon thread tape which is available at hardware stores. (Fig. 1)
2. Thread tank coupler on CO<sub>2</sub> source leaving the CO<sub>2</sub> tube receptacle facing upward. **NOTE:** TANK COUPLER SHOULD BE WRENCH TIGHT.
3. Insert aluminum threads of CO<sub>2</sub> tube into receptacle on tank coupler, turning clockwise until finger tight. **NOTE:** CO<sub>2</sub> TUBE SHOULD BE AS NEAR TO VERTICAL AS POSSIBLE. A certain amount of CO<sub>2</sub> escape between tank coupler and CO<sub>2</sub> tube is normal.
4. Turn valve on CO<sub>2</sub> source to open position.
5. Insert bleeder into black threads on CO<sub>2</sub> tube. Turn clockwise until gas escapes slowly through top of bleeder valve.
6. Watch for liquid CO<sub>2</sub> to escape from top of bleeder (white gas).
7. Turning counterclockwise, remove bleeder.
8. Turn valve on CO<sub>2</sub> source to off position.
9. Slowly remove CO<sub>2</sub> tube from tank coupler giving time for gas in coupler to escape slowly.
10. Place CO<sub>2</sub> tube on pistol. The black threads go into the gun. Turn clockwise until tube is snug.

**CAUTION:** DO NOT EXPOSE FULL CO<sub>2</sub> TUBES TO EXTREME HEAT. STORE IN COOL AREA, OUT OF DIRECT SUNLIGHT.

**IMPORTANT:** If a problem occurs with CO<sub>2</sub> tube, do not disassemble, return to factory for service.

5

**NOTE TO COMPETITORS:** Filling a CO<sub>2</sub> tube improperly or using a tube that has developed a leak may cause a problem of shortage of CO<sub>2</sub> during a match. You must **always** WEIGH YOUR CO<sub>2</sub> TUBE JUST PRIOR TO STARTING THE MATCH. Your standard Model 88 Pistol tube weighs 175 grams. It should hold approximately 40 grams of gas bringing the total weight of the tube and gas to approximately 215 grams maximum weight. This may vary slightly from tube to tube.

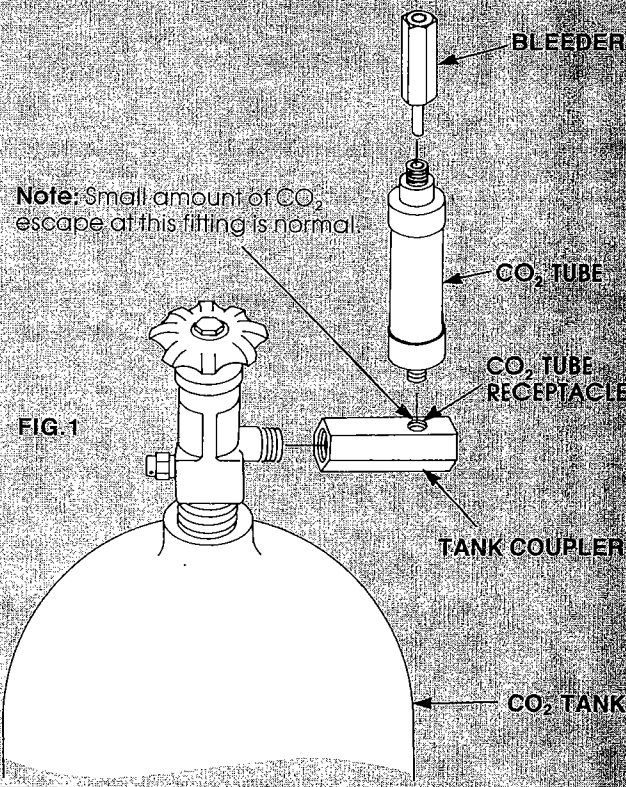

### INSERTING CO<sub>2</sub> TUBE

When inserting refill tube in pistol, the black threads go into the gun. Turn the tube clockwise until the tube is snug. When inserting tube, the pistol should be pointing slightly downward.

### COCKING, LOADING AND UNLOADING

Pull cocking lever back to the limit of its travel to cock the pistol while holding the barrel down with one finger on the cocking hand. This will prevent the barrel from snapping up. When the locking arm clears the barrel, slowly raise your finger allowing the barrel to rise smoothly. A .177 pellet can now be inserted into the barrel. Push barrel down and close the cocking lever over it. The pistol is now ready to fire. (Fig. 2)

The pressure of the cocking lever on the barrel can be adjusted by turning the adjustment screw (located on the frame directly behind the barrel) with a 1/16 inch allen wrench. Turn the adjustment screw clockwise to increase the pressure on the barrel. (Fig. 2)

To unload your pistol, point it in a safe direction and fire it. Then check to see if the barrel is clear by cocking the pistol and looking down the breech end of the barrel. If it is not clear, insert a cleaning rod into the breech and push the pellet out of the muzzle.

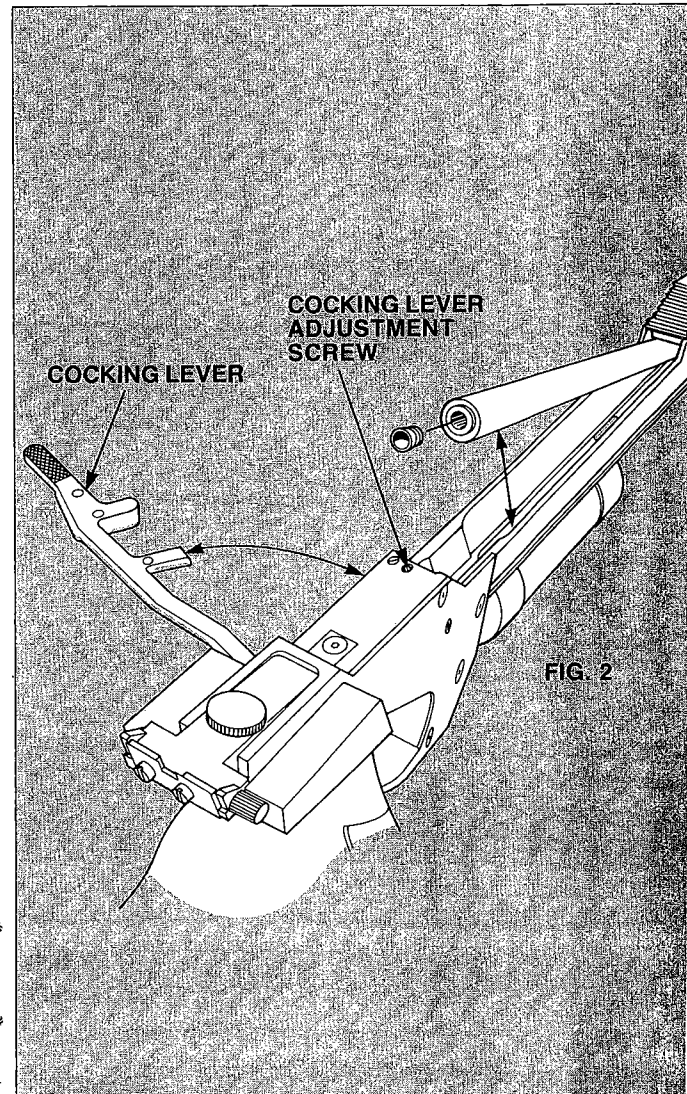

## ADJUSTING GRIP

The patented grip design allows for adjustment of the action in the grip upward or downward to suit your line of sight. Loosen the screw in the rear of the grip. Rotate the frame to the desired position and tighten screw. (Fig. 3)

This unique grip also allows for adjustment of the thickness of the grip and the heel rest so the grip will precisely fit your hand. (Fig. 4)

### Thickness

With a 4mm allen wrench, turn screw in center of left hand grip counterclockwise to loosen. Slide the front half of the grip forward or backward until desired position is obtained and then tighten the same screw. (Fig. 4)

### Heel Rest

Using a 3mm allen wrench, loosen the screw on the right side of the heel rest and the screw on the front of the heel rest. Adjust the heel rest to snugly fit your hand and tighten the screws. (Fig. 5)

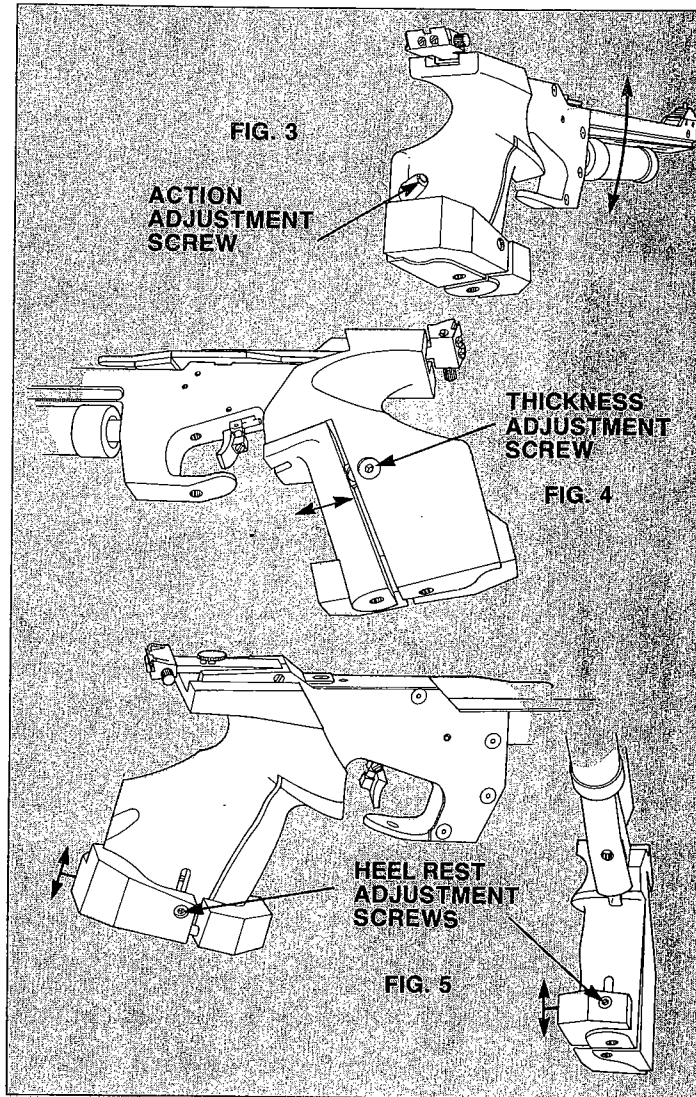

## TRIGGER ADJUSTMENTS

All adjustments to the trigger should be done slowly and carefully. These are very sensitive adjustment mechanisms that should be moved in very small increments with a 1/16 inch allen wrench. (Fig. 6).

Do not remove the adjustment screws from the pistol. In particular adjustment screws #2 and #5 if removed will allow the spring to come out of the pistol which will then require disassembly of the pistol to replace them in the proper position.

1. Length of Pretravel (First Stage) - To reduce the length of pretravel turn screw (#1) clockwise. Overadjustment clockwise will cause the gun to fire if it is cocked and will thereafter prevent the gun from being cocked. To increase the length, turn the screw counterclockwise.
2. Force on Pretravel - To increase the force, turn the pretravel spring adjustment screw (#2) clockwise. To decrease the force turn the screw counterclockwise.
3. Force on Second Stage - To increase the force of the secondary stage, turn adjustment screw #3 clockwise. To decrease the force, turn it counterclockwise. If the screw is backed out too far the gun may not cock.
4. Sear Overlap Adjustment - To obtain the minimum permissible engagement, cock the pistol, turn the sear overlap adjustment screw (#4) slowly until the gun fires without touching the trigger, then turn it back counterclockwise 1/4 turn. **CAUTION: NEVER FORGET THIS FINAL 1/4 TURN.** If overlap is adjusted marginally a hair trigger may result. This may also cause intermittent cocking.
5. After-Travel Adjustment - To reduce the travel between the trigger release point and the trigger stop, turn the adjustment screw (#5) clockwise. If the after travel is adjusted too short, the gun may not fire.

6. Trigger Shoe Adjustments - The trigger blade angle can be adjusted by loosening screw #6 and rotating the blade to the desired angle.
7. It can also be adjusted longitudinally by loosening screw #7 and moving the trigger shoe forward or back to the position you desire.

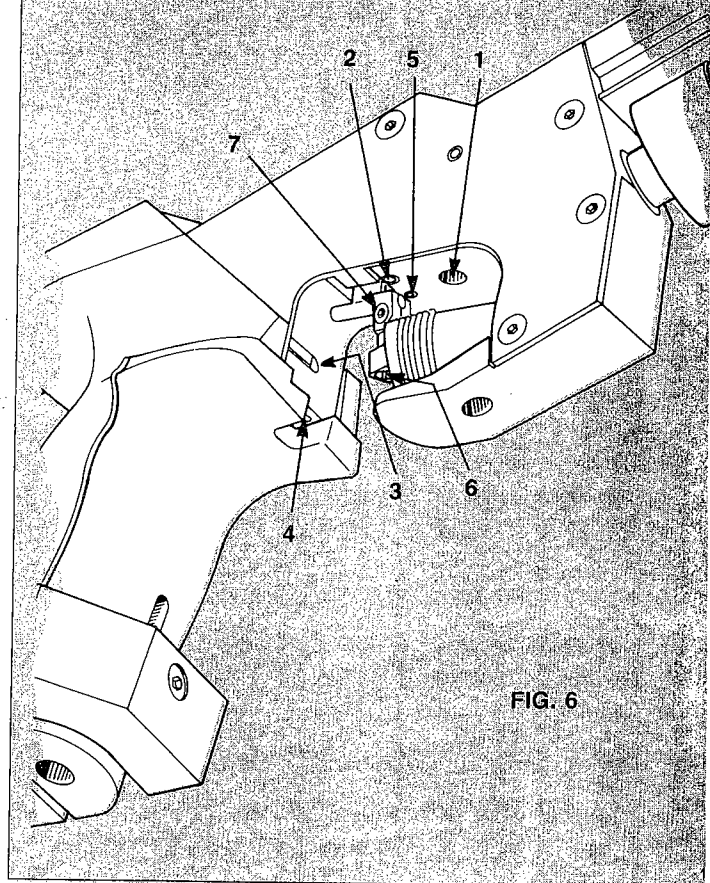

FIG. 6

## SIGHT ADJUSTMENTS

### Rear Sight

The pistol is equipped with five interchangeable rear sight blades. To change them simply loosen the two screws on the back of the blade and remove it. Replace it with the blade of your choice and tighten down the screws.

The entire rear sight can be moved forward or back toward you by loosening the rear sight base with a 1/16 inch allen wrench, moving the sight to the desired position and then tightening the screw again. (Fig. 7)

Windage - Turn the windage adjustment knob clockwise to move the rear sight to the right and counterclockwise to move it to the left. One click moves the impact point .054 inch (1.38 mm) at 10 meters. (Fig. 7)

Elevation - Turn the elevation adjustment knob counterclockwise to move the rear sight up and clockwise to move it down. One click moves the impact point .109 inch (2.76 mm) at 10 meters. (Fig. 7)

### Front Sight

The front sight is a three sided post. Each side is a different width. To change from one width to another, loosen the screw on the side of the front sight base with a 1/16 inch allen wrench, rotate the sight to the desired position and tighten the screw.

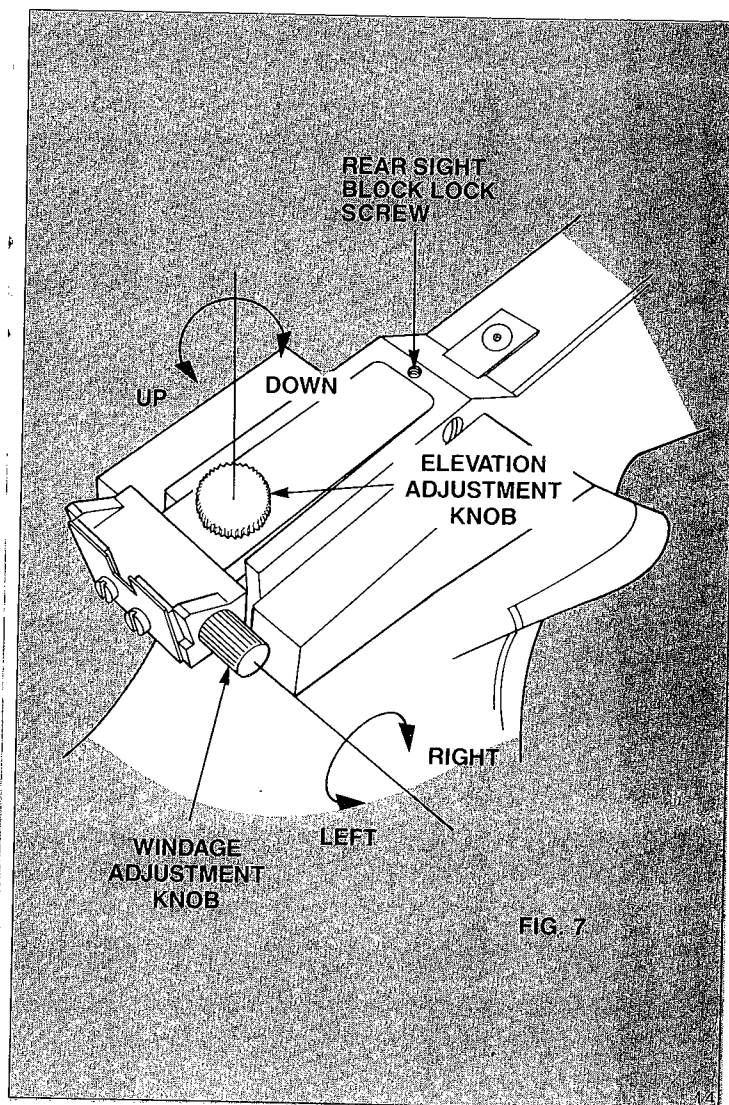



## TROUBLE SHOOTING

If the accuracy level drops on your pistol, you may be experiencing one of the following problems:

1. The CO<sub>2</sub> supply in the tube may be low.
2. The force on the cocking lever may need to be adjusted. Instructions on adjusting this are under Cocking, Loading and Unloading.
3. The pistol may be leaking in the area of the breech seal. To prevent this leakage remove the breech seal with a blunt tool, such as an allen wrench.

Turn the breech seal adjuster counterclockwise 1/8 of a turn at a time to correct the problem. If you turn the seal adjuster too far the barrel will not open. (Fig. 8)

4. The type of ammunition used in your pistol will greatly affect your accuracy levels. For optimum accuracy, use match grade pellets only.

**Repair Service:** If your pistol needs to be repaired, it should be returned to the Service Department, Crosman Airguns, Routes 5 & 20, East Bloomfield, N.Y. 14443. Do not attempt to disassemble or repair it yourself. It requires special tools and fixtures and a trained repair person to repair it correctly.

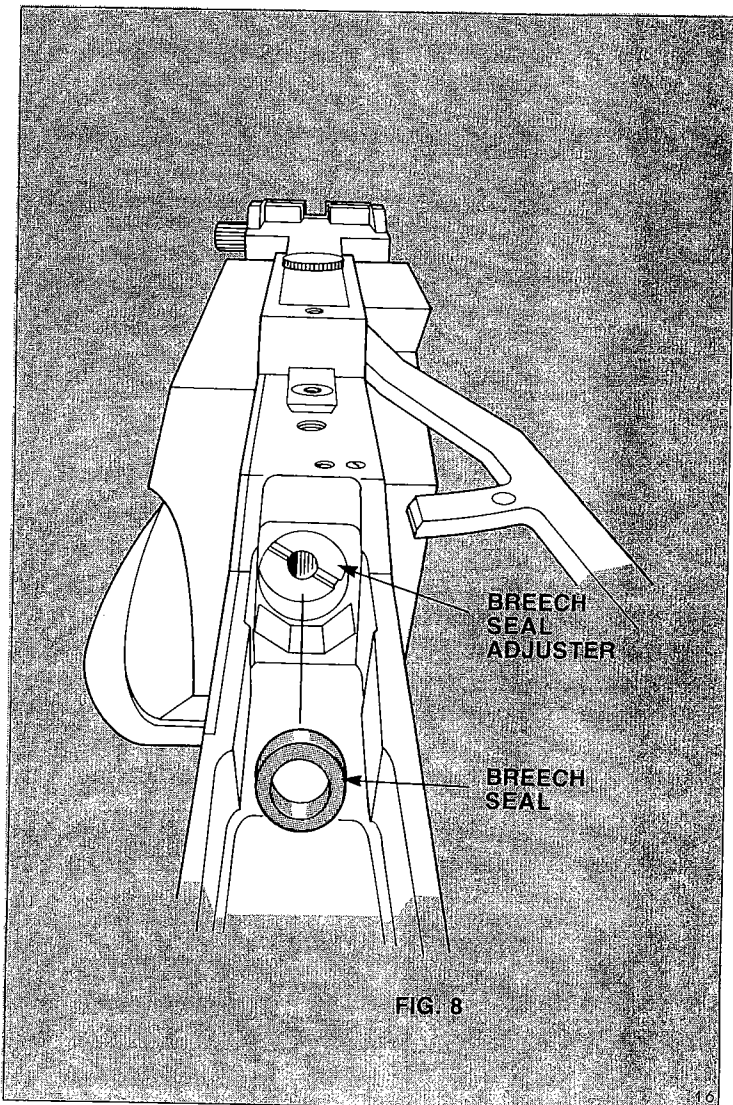

### SPECIFICATIONS

<b>Approximate Group Size</b>	6mm
<b>Pistol-Empty Weight</b>	991 g. (35 oz.)
<b>Charged Weight</b>	1031 g. (36.4 oz.)
<b>Barrel length</b>	9.94 inches (252 mm)
<b>Overall Length (without Grip)</b>	15 inches (381 mm)
<b>Trigger Pull</b>	Fully Adjustable-2 Stage
<b>Average Velocity</b>	550 fps (168 m/s)
<b>Grip</b>	Patented Design (Patent #4,630,387) Other Patents Pending. Adjustable for cant and depth with adjustable heel rest.
<b>Sight Radius</b>	14.5 inches (368 mm) maximum Adjustable
<b>Rear Sight</b>	Five interchangeable sight blades <ol style="list-style-type: none"> <li>1. .092" (2.3 mm)</li> <li>2. .112" (2.8 mm)</li> <li>3. .152" (3.9 mm)</li> <li>4. .132" (3.4 mm)</li> <li>5. .172" (4.4 mm)</li> </ol>
<b>Front Sight</b>	3-sided Rotating Post <ol style="list-style-type: none"> <li>1. .197" (5 mm)</li> <li>2. .156" (4mm)</li> <li>3. .236" (6mm)</li> </ol>

17

### LIMITED ONE YEAR WARRANTY

This product is warranted to the retail consumer for one year from date of purchase against defects in material and workmanship and is transferable.

**What is Covered:**

Replacement parts and labor. Transportation charge to consumer for repaired product.

**What is Not Covered:**

Transportation charges to Crosman for defective product. Damages caused by abuse or failure to perform normal maintenance. Sales outside of the United States. Any other expense. CONSEQUENTIAL DAMAGE, INCIDENTAL DAMAGES, OR INCIDENTAL EXPENSES, INCLUDING DAMAGE TO PROPERTY. SOME STATES DO NOT ALLOW THE EXCLUSION OR LIMITATION OF INCIDENTAL OR CONSEQUENTIAL DAMAGES, SO THE ABOVE LIMITATION OR EXCLUSION MAY NOT APPLY TO YOU.

**How to Obtain Warranty Performance:**

Attach to Product your name, address, description of problem, and phone number. Package and return Product to Crosman Airguns, Service Department, Routes & 20, East Bloomfield, New York 14443. In United Kingdom, package and return to Coleman U.K., Paris Wharf Estates, Harbour Road, Portishead, Bristol. U.K. BS209BA.

**Implied Warranties**

ANY IMPLIED WARRANTIES, INCLUDING THE IMPLIED WARRANTIES OF MERCHANTABILITY AND FITNESS FOR A PARTICULAR PURPOSE, ARE LIMITED IN DURATION TO ONE YEAR FROM DATE OF RETAIL PURCHASE. SOME STATES DO NOT ALLOW LIMITATIONS ON HOW LONG AN IMPLIED WARRANTY LASTS, SO THE ABOVE LIMITATION MAY NOT APPLY TO YOU.

To the extent any provision of this warranty is prohibited by federal, state, or municipal law which cannot be preempted, it shall not be applicable. This warranty gives you specific legal rights, and you may also have other rights which vary from state to state.