

INSTRUCTION SHEET FOR NO. 1300 BENJAMIN SUPER 50-SHOT BB REPEATER AIR PISTOL KEEP FOR FUTURE REFERENCE

THIS GUN HAS BEEN CAREFULLY TESTED for compression and accuracy by shooting it several times before passing our inspection. The operation of same is under your control and it will give satisfactory results if instructions are followed.

KNOW YOUR GUN. It is important that you understand how gun operates to obtain satisfactory performance. Use gun often as frequent operation keeps Piston and Valves flexible.

KEEP (1) or (2) pumps in Air Gun when not in use to help keep Valves seated.

USUALLY THERE IS NOTHING SERIOUSLY WRONG with a new gun. Any failure is due to damage in shipment or one of the following reasons: SAFETY IS ON; gun has been pumped up too much; Shot Barrel is jammed; Valve is unseated; examine Pump Piston; check Trigger.

BEFORE PUMPING PISTOL UP PUT SAFETY ON. Slide Filler Hole Cover on Magazine to expose Filler Hole and FILL Magazine with LEAD or STEEL AIR RIFLE (BB) SHOT. Slide cover over Hole in Magazine.



TO PUMP PISTOL hold it in left hand and pull Pump Lever out until Pump Piston passes air intake hole, then push Pump Lever back against pump barrel. Pump 5 or 6 strokes for ordinary use; 10 or 12 strokes will give maximum shooting force. It is necessary to pump this model up after each shot.

SHOOTING FORCE IS ADJUSTABLE. You can determine number of pumps needed for various uses after a little practice.

IF GUN IS HARD TO PUMP you may be pumping against a full Air Chamber or Pump Cylinder is dry.

LUBRICATE PUMP CYLINDER if Pump Piston binds; keep Felt Washer oiled; spray a little fine graphite or light machine oil in air hole of Pump Barrel. Do not lubricate Pump Cylinder excessively as oil may be forced into Air Chamber when pumping; this may damage valve packing.

SOMETIMES VALVES LEAK on first pump, but usually seat themselves after pressure is raised in Air Chamber unless Valves are worn or unyielding. If there is no pressure in Air Chamber when you start pumping try cocking the Hammer which will take pressure off of Outlet Valve. You should keep a light charge of air in gun when not in use.

DO NOT PUMP THESE GUNS UP TOO MUCH as excessive internal pressure will not permit Outlet Valve to open up wide when firing, owing to air pressure being greater than blow of Hammer, which reduces shooting force; excessive strain will bend or buckle Pump Lever. Both Valves are often damaged when gun is overpumped and must be replaced even in new guns. To reduce excessive internal pressure continue to fire blank as often as it is necessary until Air Chamber is empty.

DO NOT DRY FIRE GUN UNLESS SHOT MAGAZINE IS EMPTY.

AFTER GUN IS PUMPED UP Turn No. 165 Button on Bolt to left until pin clears Breech Cap and PULL BOLT STRAIGHT BACK All the way until 103 Trigger engages No. 192 Hammer, when you will hear a click. Hold MUZZLE end of Gun Barrel slightly above level; while Bolt is pulled back (1) Round Shot will automatically drop in Bolt. Push Bolt in and lock it. This seals Breech End of Shot Barrel and prevents air from escaping at this point when gun is fired. This also advances Shot in Bolt to firing position.

ALWAYS KEEP SAFETY ON until you are ready to shoot to prevent accidental discharge.

DO NOT PUT GUN AWAY WHEN CHARGED WITH AIR AND DO NOT FIRE GUN UNLESS IT IS CHARGED WITH AIR. No. 103 Hair Trigger has smooth pull between 2 and 3 pounds same as used in fire arms.

USE GUN OFTEN as frequent operation keeps Valves and Pump Washer flexible. DO NOT OIL VALVES or allow any oil to reach Valves from Pump Cylinder. We usually use oil proof valve packing, however, we reserve the right to substitute other suitable materials when it is not available.

ALL COMPRESSED AIR DEVICES USE A PLUNGER OR PISTON for Compressing Air into a tank or chamber which is equipped with valves, and the valves must be seated to hold air pressure.

THESE GUNS HAVE SELF EXPANDING NO. 1351 HYCAR PISTONS which may be replaced when worn or damaged. The Air is Compressed with a hand operated Pump and forced into Air Chamber through Inlet Valve. Outlet Valve releases Compressed Air when Gun is Fired.

TO REMOVE PUMP ASSEMBLY pull Pump Lever up as far as it will go; remove No. 1304 Lock Screw from end of No. 1324 Muzzle Plug and push out No. 1311 Plug Hinge Pin, then pull out Muzzle Plug and bring No. 1325 Link Coupling Pin in line with Plug Hinge Pin Hole and push Link Coupling Pin out through this hole, after which take Pump Assembly out.

TO REPLACE PUMP PISTON loosen No. 1321 Pump Lock Nut; detach No. 1351 Pump Piston, remove No. 1336 Felt Oiler and No. 1344 Iron Washer. Put Lock Nut on New Pump Piston and assemble with Iron Washer, also Felt Oiler in Link Coupling so that overall length from edge of Link Coupling to edge of Pump Piston measures 2-13/16 inches; be sure to tighten Lock Nut in correct position. Wipe inside of Pump Barrel thoroughly before putting Pump Assembly back as follows: hold Pump Barrel in one hand so that slot in Pump Barrel is up or on top, then rotate Pump Piston gently to and fro, also guide Pump Piston into Pump Barrel with fingers and push Pump Piston in. After this reverse above operations by putting back Link Coupling Pin through Plug Hinge Pin Hole, then put Muzzle Plug in end of Pump Barrel and insert Lever Hinge Pin so that groove is under Lock Screw which will hold it in place when tightened.

IF GUN HAS NOT BEEN USED FOR SOMETIME and cannot be pumped up or does not hold AIR, it can be RE-PAIRED.

OUR WARRANTY REQUIRES PURCHASERS to mail Registration Card to Factory promptly and WRITE FACTORY about NEW GUNS that are not entirely satisfactory. ADVISE Model and from whom Gun was received or purchased also Price paid and what the Trouble is, etc. so we can recommend proper care or handling of gun. WE DO NOT REPLACE GUNS or authorize Dealers to exchange them, and we will not Service Guns purchased at Reduced Prices—UNDER WARRANTY.

WE GUARANTEE SATISFACTORY PERFORMANCE AND WILL SERVICE NEW GUNS purchased at Regular Prices FREE OF CHARGE under WARRANTY if RETURNED TO FACTORY PREPAID within a reasonable time, providing Registration Card was mailed to Factory promptly and Guns have not been damaged or abused and do not show excessive wear.

SOME OF OUR DEALERS are equipped to SERVICE BENJAMIN under WARRANTY and to repair worn guns. Ask us for the local Authorized Repair Depot in your Area, or advise nearest Large Cities.

YOU CAN MAKE YOUR OWN REPAIRS. ORDER Parts and Valve Tool from Factory if not available from Dealer. List Parts wanted by number in accordance with Price List. Advise Model and enclose payment with Orders. WE DO NOT SHIP C.O.D.

BE SURE THAT AIR CHAMBER IS EMPTY BEFORE REMOVING VALVES.

TO REMOVE VALVES take out all of the parts in breech end of large barrel down to No. 140 Outlet Valve Lock Screw. Place small end of Valve Tool in square hole of Outlet Valve Lock Screw and remove Outlet Valve Lock Screw by unscrewing it. You can hold Valve Tool in vise horizontally and push breech end of large barrel over small end of Valve Tool, then turn gun slowly to left which will loosen Outlet Valve Lock Screw; do not use wrench or pliers on gun. Or you can hold gun barrel in vise between two wooden jaws which have been bored out to accommodate same; do not put a lot of pressure on gun barrel, just enough to hold it safe. Insert small end of Valve Tool in Outlet Valve Lock Screw and remove it by turning Valve Tool slowly to left (with open end wrench) to loosen it. Next you attach small end of Valve Tool (which is bored out and threaded in center) to threaded section of No. 137 Outlet Valve Seat; hold Valve Tool in vise horizontally and pull gun away to remove Outlet Valve Seat; you may tap end of gun barrel lightly around the circumference with a wooden mallet to break lead seal. Outlet Valve Seat was screwed down tight against a lead packing ring by tightening Outlet Valve Lock Screw against it when gun was assembled, and cannot be removed unless these instructions are followed.

VALVE ASSEMBLY WILL FALL OUT by inverting gun barrel. If No. 135 Inlet Valve sticks to Inlet Valve Seat and does not fall out of its own weight, you may be able to jar it loose; or push a thin stiff wire through air intake hole in Inlet Valve Seat against Inlet Valve to loosen it - from muzzle end of large barrel after pump assembly is removed. Wipe out Air Chamber with a soft cloth wrapped around a small stick then clean or replace both valves if necessary.

DROP NO. 135 INLET VALVE in Air Chamber with packing against Inlet Valve Seat; next comes 145 Outlet Valve Spring; next drop No. 131 Lead Packing Ring in Air Chamber. Attach hollow end of Valve Tool to threaded section of No. 137 Outlet Valve Seat and screw it down tight by hand; place stem of No. 134 Outlet Valve in Outlet Valve Seat; insert Outlet Valve and Outlet Valve Seat in Air Chamber; with key on Outlet Valve Seat fitting in slot of Air Chamber; push Valve Tool in (all the way) and hold it there, then tap end of Valve Tool sharply with hammer; this spreads No. 131 Packing Ring and holds Outlet Valve Seat in fixed position. Unscrew Valve Tool from Outlet Valve Seat; drop No. 133 Lead Packing Ring with tongue on extension on it over Outlet Valve Seat, with tongue on Lead Packing Ring fitting in slot of Air Chamber. Place No. 140 Outlet Valve Lock Screw on end of Valve Tool and screw it down on Outlet Valve Seat in Air Chamber; tighten Outlet Valve Lock Screw by turning Valve Tool to spread both Lead Packing Rings. Complete Air Chamber cannot be replaced.

IF YOU PREFER TO SHIP GUN DIRECT TO FACTORY FOR ADJUSTMENT OR REPAIRS IT MUST BE FORWARDED BY EXPRESS PREPAID AND we will return it to you Express Collect F.O.B. Factory. Send full instructions by first class mail.

AIR PISTOLS ARE NOT ADMITTED IN U.S. Mail between individuals and Factory under Postal Regulations; we cannot change this situation. AIR PISTOLS CAN BE SHIPPED BY PARCEL POST TO OR FROM FACTORY AND LICENSED FIRE ARMS DEALER.

ASK ANY GUN DEALER in your community to ship BENJAMIN PISTOLS TO Factory by Parcel Post for Adjustment or Repairs when needed. Dealer must also send

us full instructions by separate mail at the same time shipment is forwarded; if correspondence is enclosed with gun by Parcel Post, package must be endorsed accordingly and additional postage paid on it (under present P.O. Regulations). Dealer is entitled to make a nominal Service Charge for handling Repair Jobs in addition to cost of repairs and transportation.

IF ADJUSTMENT IS EXPECTED UNDER WARRANTY we must have complete information including date when purchased and price paid. Unless instructions are in our hands when gun reaches us we cannot proceed with repairs in the regular way, which entails additional time and expense. WE DO NOT MAKE PARTIAL REPAIRS and we will not assume any responsibility for satisfactory operation unless we make complete repairs.

WE DO NOT USUALLY REFINISH worn guns as it is necessary to strip them completely. Our charge for refinishing Gun is \$5.00 in addition to cost of repairs. You can obtain black lacquer or air drying enamel from local paint store for refinishing Gun.

DO NOT WRITE US about repair jobs or orders sent in by Dealers as it would be difficult for us to identify them. Ask the Dealer to write to us and we will give him complete information upon receipt of order number or other references which will enable us to investigate it.

SHOOTING HIGH OR LOW IS NOT A DEFECT and can be easily corrected by drawing a fine or coarse bead on front sight when aiming.

OPEN REAR SIGHT IS ADJUSTABLE FOR ELEVATION AND WINDAGE and can be moved either right or left or up or down. If gun shoots to the right move the rear sight to the left to correct it. If gun shoots high, lower the rear sight to correct it. Before making any sight correction you should have a shot group of 5 or more shots very close together to make sure that you are aiming and squeezing the trigger properly. If gun shoots much too low you can file top of front sight off which will raise muzzle end of gun barrel. You cannot check these guns for accuracy in a vise as it would be almost impossible for anyone to replace the gun in exactly the same position after it has been taken out of the vise for pumping up. The practical way to test these guns for accuracy is to put them in a V rest permanently located on a post or other support and bring shot barrel into the same position for each shot by holding it against a stop.

IF YOU INQUIRE ABOUT ORDERS FOR TOOLS AND PARTS OR SUPPLIES sent to Factory give us the approximate date of order and advise amount paid if any, either money order, postal note, bank draft, personal check, currency, or coin. Send us a copy of order or make up another list and ENCLOSE ALL PREVIOUS CORRESPONDENCE in connection with it. We cannot investigate orders over 12 months old or investigate them without complete information as requested.

IF SHIPMENT IS RECEIVED IN BAD ORDER FROM US or you discover that the contents are damaged be sure to notify the Postmaster or Express Agent in your city immediately, also write us promptly and return the damaged goods to us PREPAID, and we will file claim for damages.

SEND MONEY ORDER OR BANK DRAFT with orders for Supplies and Parts if prompt shipment is wanted. Allow time for personal checks to clear. INCLUDE 50¢ for PACKING AND POSTAGE with orders for Parts and Supplies under \$5.00; over this amount add 10¢ for shipping charges in U.S.A.; extra for AIR MAIL shipments. INCLUDE 2% SALES TAX with orders originating in MISSOURI. WE DO NOT SHIP C.O.D. Overpayment will be applied to additional merchandise or refunded in U.S. Postage. ENCLOSE U.S. STAMPED SELF-ADDRESSED ENVELOPE with all inquiries to Factory.

NO. 1300 REPAIR PARTS - DESCRIPTION OF PARTS AND PRICE LIST

Parts marked * not subject to replacement - do not order

101	Breech Cap (State Model) . . .	\$0.35	1071	Magazine Fastening Screw05
102	Breech Cap Screws . . . each	.05	1073	Magazine (Includes 1083) . . .	1.50
103	Trigger75	1077	Retainer Screw in end of Magazine25
104	Trigger Pin10	1080	Spring Ring Stop in Bolt05
130	Stock Screws each	.05	1083	Magazine Plug (See 1073) . . .	*
131	Outlet Port Packing Ring25	1302	Pump Lever75
134	Outlet Valve75	1303	Pump Link50
135	Inlet Valve50	1304	Lever Hinge Pin Lock Screw . .	.15
137	Outlet Valve Seat50	1306	Trigger Spring25
140	Outlet Valve Lock Screw50	1308	Air Chamber	*
145	Valve Spring50	1310	Handle Pins each	.05
153	Safety Spring10	1311	Lever Hinge Pin10
154	Safety Button35	1314	Link Hinge Pin10
156	Ball Bearing10	1316	Rear Sight Fastening Screw . .	.10
158	Bolt Button Spring Washer10	1317	Lever Handle75
162	Relay Bearing	*	1321	Pump Lock Nut15
165	Bolt Button (Includes Lock Pin)25	1323	Link Spring25
168	Bolt Guide Screw15	1324	Muzzle Plug75
188	Trigger Relay Pin10	1325	Link Coupling10
189	Trigger Relay (Sear) Includes 16290	1328	Front Assembly Screw10
190	Bolt Button Screw10	1331	Outlet Valve Lock Nut Packing Ring25
192	Hammer (Includes 193)85	1336	Felt Oiler15
193	Hammer Pin (See 192)10	1342	Link Coupling75
195	Hammer Spring25	1344	Small Iron Washer10
196	Bolt Friction Spring10	1349	Pump Barrel	*
197	Ball Bearing10	1351	Pump Piston75
1013	Shot Barrel	*	1364	Rear Assembly Screw10
1020	Magazine Slide Cover15	1391	Frame Dowel Pin10
1022	Gun Barrel	*	13039A	Stock Frame	2.50
1026	Front Sight	1.50	13039L	Left Hand Stock, Plastic75
1027	Rear Sight50	13039R	Right Hand Stock, Plastic75
1066	Bolt	1.50			

SUPPLIES, TOOLS AND PARTS - (Subject to change)

BENJAMIN Steel Air Rifle Shot, per lb.	\$1.00
BENJAMIN Steel Air Rifle Shot, per 500	.40
BENJAMIN Lead Air Rifle Shot, per lb.	1.00
BENJAMIN Lead Air Rifle Shot, per 500	.50
BENJAMIN Bulls-Eye BELL TARGET, Each	2.50
BENJAMIN Paper Target Inserts, 25 Ft. Pistol, per 100-50¢; per 500-\$2.40; per 1000	4.50
BELT TYPE LEATHER HOLSTER with snap buttons on belt loop and safety strap. R or L; ADVISE MODEL when ordering to obtain correct size	4.00
Combination Valve Tool for Removing Outlet Valve Lock Screw and Extracting Outlet Valve Seat	1.00

Combination Valve Tool	\$1.00
One No. 134 Outlet Valve75
One No. 131 Outlet Part Packing Ring25
One No. 1331 Outlet Valve Lock Nut Packing Ring25
One No. 1351 Hycar Pump Piston75
One No. 1336 Felt Oiler15
Packing and Postage50
	<u>\$3.65</u>

ORDER PARTS BY NUMBER AS NEEDED. Advise Model and enclose payment with Orders.

SEND MONEY ORDER OR BANK DRAFT with orders for Supplies and Parts if prompt shipment is wanted. Allow time for personal checks to clear. INCLUDE 50¢ for PACKING AND POSTAGE with orders for Parts and Supplies under \$5.00; over this amount add 10% for shipping charges in U.S.A.; extra for AIR MAIL shipments. INCLUDE 2% SALES TAX with orders originating in MISSOURI. WE DO NOT SHIP C.O.D. Overpayment will be applied to additional merchandise or refunded in U.S. Postage.

BENJAMIN AIR RIFLE CO.

Printed in U.S.A. 0458 15M

1525 So. 8th St.

St. Louis 4, Mo.

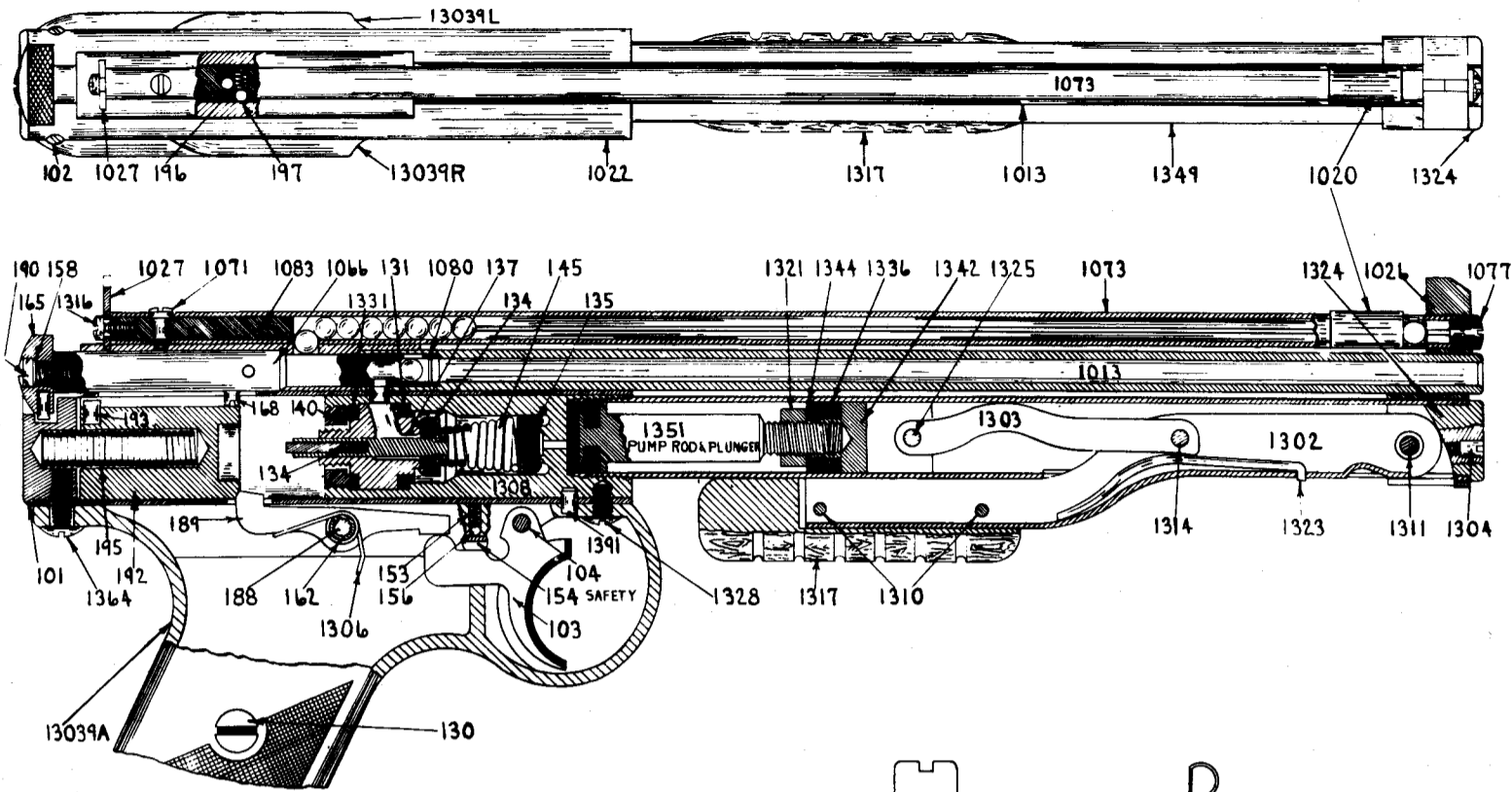

1027



1080

