

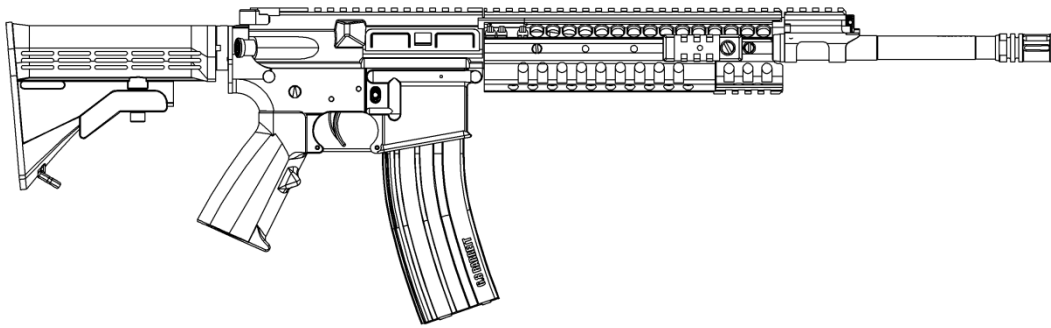

REC 7



Operator's Manual

September 26, 2008

USE OF THIS MANUAL

Before you handle the REC7 rifle, read this manual in its entirety. It is important that you understand the principles of safe gun handling in general and the unique features of this rifle. This manual is not a substitute for training from a qualified instructor. Important safety topics are discussed in this chapter and throughout this manual. This manual should remain with the rifle and it should be transferred with the rifle to subsequent owners. Additional manuals can be ordered from Barrett Firearms Manufacturing or can be downloaded from the company website.

This manual covers all variants of the REC7. Technical specifications are subject to change without notice.

SAFETY GUIDELINES

WARNING

Failure to follow safety guidelines may cause injury or result in death.

Ammunition

Barrett does not condone the use of hand loaded, remanufactured, or surplus ammunition. The use of clean, dry and properly stored commercially manufactured ammunition will preserve your warranty.

Do not mistake the 6.8 SPC cartridge with the .223/5.56mm cartridge. Do not use .223/5.56mm magazines, muzzle brakes, flash hiders, sound suppressors, or blank firing attachments on your 6.8 SPC caliber rifle.

WARNING

Mixing components can result in rifle damage and personal injury.

Headspace

Do not insert bolt assemblies from one rifle into another rifle.

Safety Distance

Bullets fired from this rifle may travel several miles. Make certain that you have an adequate backstop.

Hearing protection

Hearing loss is permanent. Hearing loss from gunfire is cumulative, but the noise from even one shot may cause permanent loss. Wear both ear plugs and ear muffs. It is also your responsibility to protect the hearing of those around you.

Eye Protection

Eye protection should be worn when both shooting and maintaining your rifle. It is normal for firing to generate air born dust and debris. Protect your eyes from solvents and uncaptured parts under spring pressure while performing maintenance on your rifle.

Assume every gun is loaded

Until you personally prove otherwise, treat every gun as if it were loaded. Do not trust your memory and do not take anyone else's word for it. Look and feel for an empty chamber. Do not trust the extractor to provide an empty chamber.

Beware of barrel obstructions

Ensure the barrel's bore is free of obstructions before you fire your rifle. Even the smallest obstruction such as a stuck patch or even grease will cause increased pressures that can rupture the barrel.

Muzzle control

Always keep the muzzle pointed in a safe direction. Never allow your muzzle to point at anything that you do not intend to shoot.

Keep your finger off the trigger

Keep your finger off the trigger and out of the trigger guard until your sights are aligned on your target and you intend to fire.

Keep your safety on

Keep your safety on until your sights are aligned on your target and you intend to fire.

Identify your target and backstop

Before you pull the trigger, make certain of your target and what is beyond it. The rifle should never be fired at surfaces where bullets are likely to ricochet in unpredictable directions.

Failure to fire

If your rifle fails to fire when you pull the trigger, do not retract the charging handle to open the action. Keep the rifle pointed toward a safe area and wait two minutes. If a hang fire (slow ignition) has occurred, the round may fire within two minutes. If the round does not fire, remove and inspect the cartridge. If the primer is indented properly, discard it in a safe manner.

Maintain your rifle properly

Performing proper maintenance, as outlined in this manual, ensures that your rifle will be safe to shoot and will perform to design specification for many years. Alterations, modifications or adjustments may damage your rifle, make it unsafe to fire and will void warranty claims.

Store your rifle safely

Even though your rifle represents a significant financial investment, the greatest value in keeping it secured is preventing it from falling into the hands of a child, a careless adult, or a thief. It is your responsibility to take every reasonable precaution to secure your rifle.

Alcohol, medications and drugs

Do not handle or operate your rifle under the influence of alcohol, medication or drugs.

WARRANTY AND SERVICE

Barrett Firearms Manufacturing Inc. (BFMI), warrants that this firearm was manufactured free of defects in materials and workmanship. For one year from the date of purchase by the original owner, BFMI agrees to correct any defect in this firearm for the original purchaser by repair or replacement with the same or comparable model.

BFMI will not be responsible for injury, death, or damage to property resulting from either intentional or accidental discharge of this firearm or from its function when used for purposes or subjected to treatment for which it was not designed. BFMI will not honor claims involving this firearm which result from careless or improper handling, unauthorized adjustment or parts replacement, corrosion, neglect, the use of the wrong caliber ammunition, or the use of other than commercially manufactured ammunition in good condition, or any combination thereof.

If you need factory service, whether made under warranty or not, please contact BFMI for instructions on how to have your firearm repaired.

Barrett Firearms Manufacturing Inc.
P.O. Box 1077 Murfreesboro, TN
37133-1077 615-896-2938

www.barrettrifles.com

Your Responsibility

Your Barrett firearm is well-engineered and manufactured to the highest standards. It was carefully inspected before it was packaged and shipped from our factory. Its safe use depends on you alone. You are the ultimate safety device. Much like other mechanical devices, such as a power tools, gas-powered lawn equipment, and automobiles, your firearm is safe unless handled in an irresponsible or uneducated manner.

TABLE OF CONTENTS

Use of this manual	1
Safety	2-3
Warranty and Service	4
Table of contents	5
Specifications	6
Contents	7
Function	8
Break-in	8
Loading	9-10
Unloading and Clearing	11-13
Disassembly and Assembly	14
Disassembly of Upper Receiver Components	15
Disassembly of the Bolt Carrier Assembly	16
Disassembly of the Bolt	16
Disassembly of the Piston System	17
Disassembly of the Piston System (If Applicable)	18
Front and Rear Sight Adjustment	19-20
Removal of Handguard	21
Disassembly of Lower	22
Cleaning and Lubrication	23
Operating Under Unusual Conditions	24
Troubleshooting	25
Exploded Views and Parts Lists	26-27
Exploded Views and Parts Lists	28-29

SPECIFICATIONS

BARRETT REC7

CALIBER	6.8mm x 43 mm
BARREL LENGTH	16 Inches
OVERALL LENGTH (STOCK COLLAPSED)	33.25 inches
OVERALL LENGTH (STOCK EXTENDED)	36.625 inches
WEIGHT (WITHOUT MAGAZINE)	7.62 pounds
MAGAZINE WEIGHT	0.56 pounds
MAGAZINE WEIGHT (30 CARTRIDGES)	1.62 pounds
TWIST RATE	1 turn in 10 inches, right hand
NOMINAL MUZZLE VELOCITY	2550 ft/sec
SAFETY	Manual, thumb lever
SCOPE RAIL	Parallel with bore, Mil-Std 1913

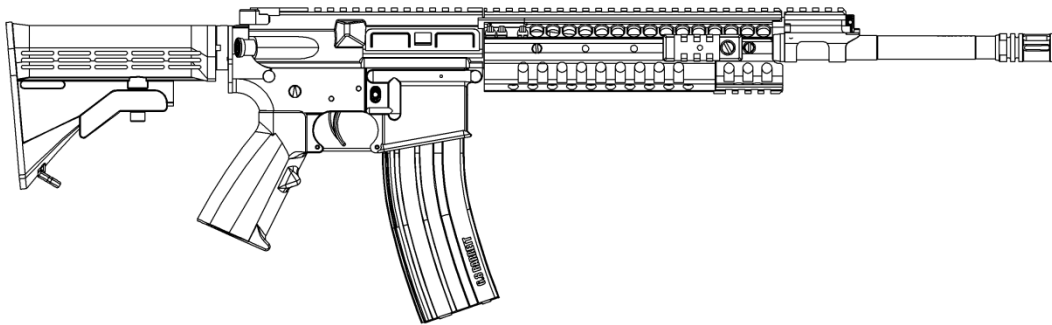

Figure 1. REC7

CONTENTS

Your REC7 rifle system includes the following:

REC7 Rifle

1 Magazine

Operator's Manual

The rifle is shipped from the factory fully assembled.

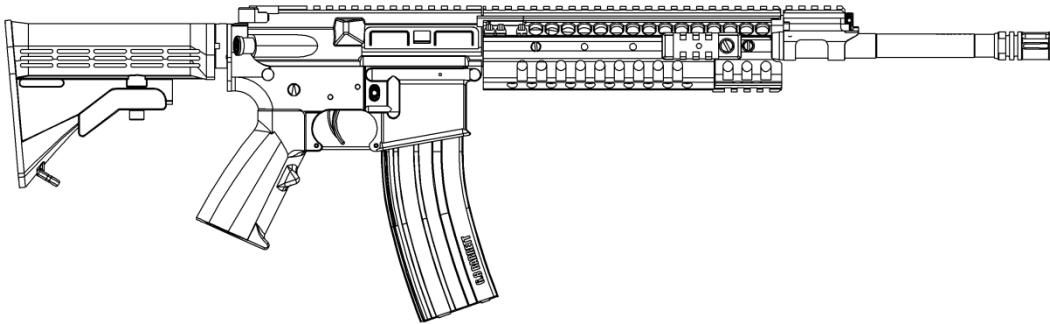

Figure 2. Fully assembled rifle with magazine installed.

FUNCTIONS AND FEATURES

The REC7 is a self-loading, gas piston-operated, magazine-fed, shoulder fired rifle that includes a flash hider. User selected accessories may be mounted on Mil-Std 1913 rail segments on all four quadrants of the handguard. The chamber and bore are chrome plated. The gas block serves as a housing for the gas plug and offers additional mounting space for accessories on the Mil-Std 1913 rail.

BREAK-IN PROCEDURE

Because individual barrels, powder, primer and bullet combinations vary widely and because shooters have strongly held personal opinions on the subject, Barrett does not offer a specific procedure for barrel break-in. Barrett does recognize that a clean barrel shoots better. Barrett also recommends that you do not overheat your barrel, especially your new barrel. Experience has shown that the bore becomes less prone to fouling over time and that accuracy may increase as this occurs.

LOADING

WARNING
Point muzzle in a safe direction.

1. Insert a loaded magazine fully into the magazine well. Insert the magazine until the magazine catch engages and holds the magazine. Tap the magazine upward to ensure the magazine is fully seated. (Figure 3).

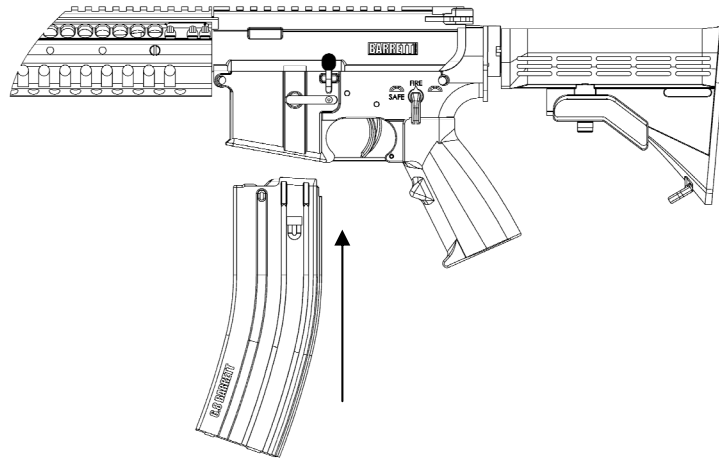

Figure 3.

2. Before pulling the charging handle, disengage the charging handle lever with index finger on left side of handle. Pull charging handle back with index and middle fingers. Once the charging handle is in the rear most position, release handle with both fingers and let the handle pull forward without any assist. This will ensure the full force of the buffer spring is utilized to chamber the first round. (Figure 4).

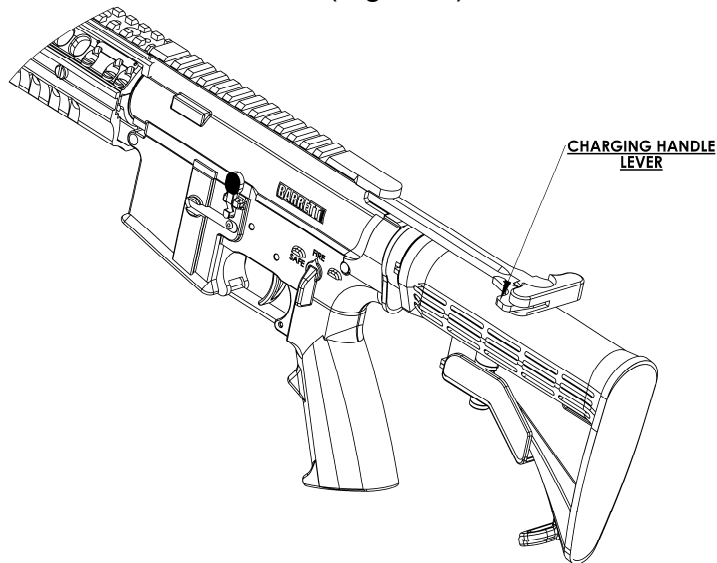

Figure 4.

LOADING

3. Place safety selector switch to SAFE position until ready to operate. (Figure 5).

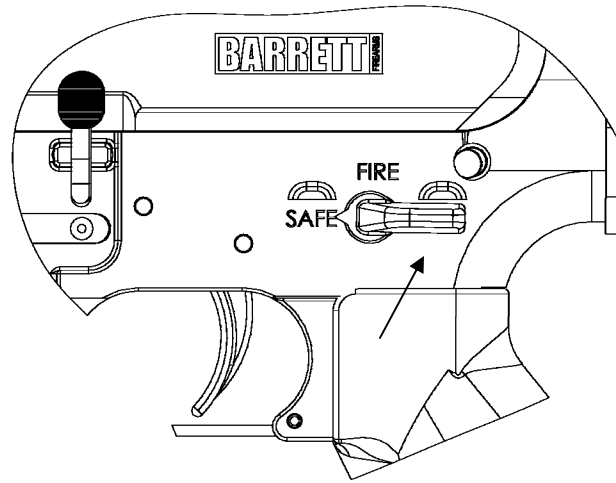

Figure 5.

Note

The hammer must be cocked in order for the selector to be placed on "SAFE".

FIRING

Move the selector switch to fire to enable trigger movement to fire. (Figure 6).

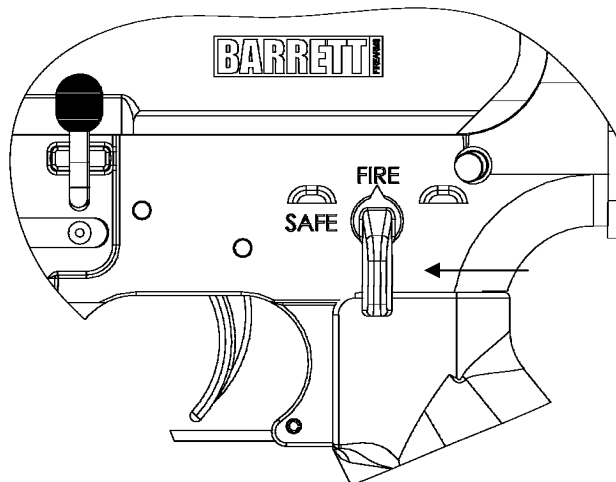

Figure 6.

UNLOADING AND CLEARING

Note

The hammer must be cocked in order for the selector switch to be placed on "SAFE"

1. If able, place the selector switch on SAFE. (Figure 7).

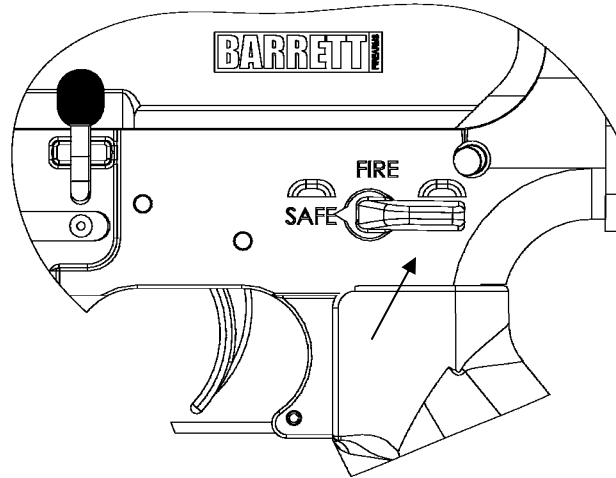

Figure 7.

Note

The cartridge magazine should drop from the magazine well by its own weight.

2. Remove the magazine by depressing the magazine catch button and assisting the cartridge magazine down. (Figure 8).

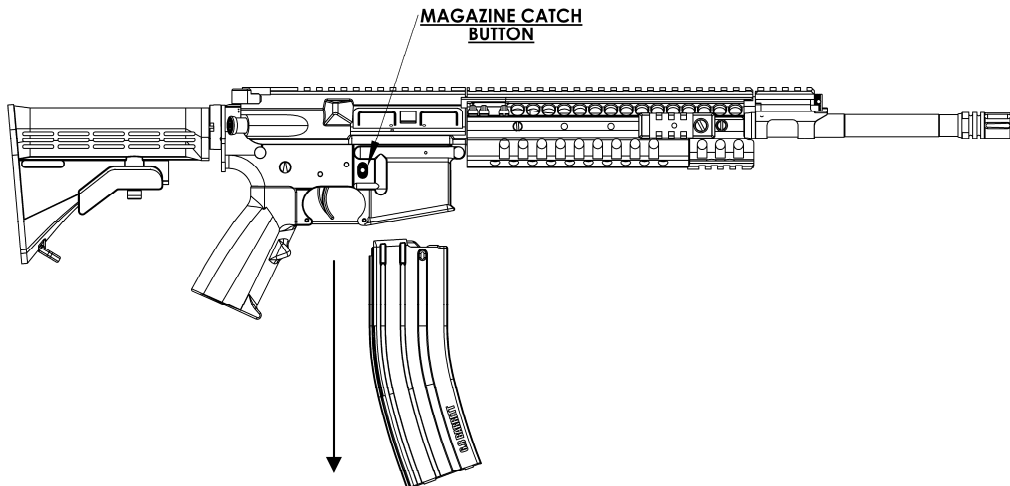

Figure 8.

UNLOADING AND CLEARING

3. To lock the bolt open, pull the charging handle and hold it rearward. (Figure 9). While holding the charging handle rearward, depress the bottom of the bolt catch. (Figure 10). Push the charging handle forward until it latches. (Figure 11).

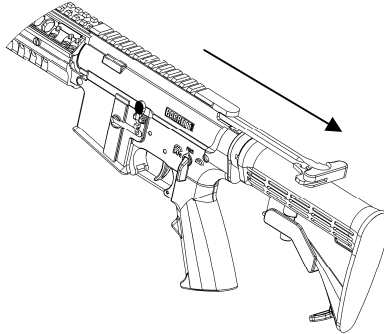

Figure 9

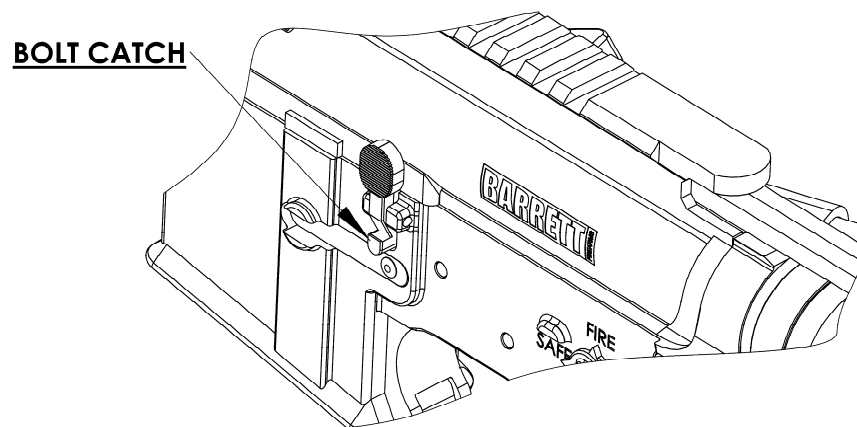

Figure 10

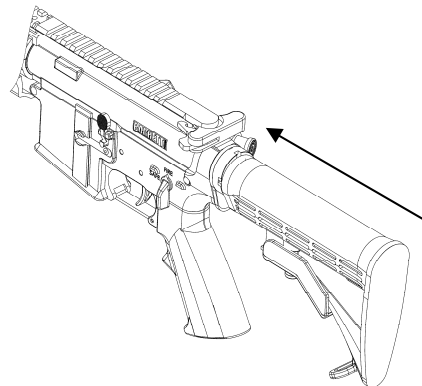

Figure 11

UNLOADING AND CLEARING

4. Visually and physically inspect the chamber to ensure that it is empty. (Figure 12).

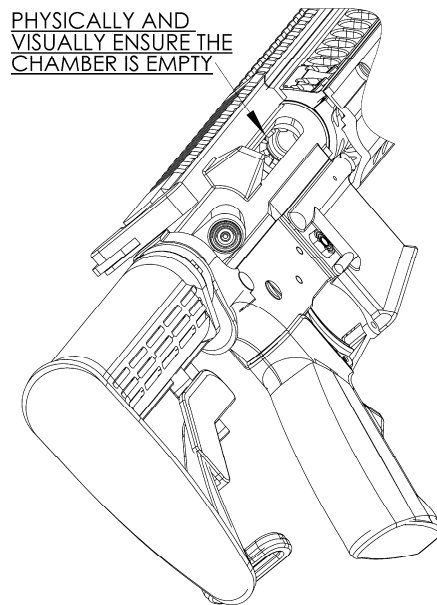

Figure 12.

5. Place the selector switch on SAFE. Press the upper portion of the bolt catch to allow the bolt assembly to close. (Figure 13). Repeat steps 3-5 to ensure rifle is unloaded and cleared.

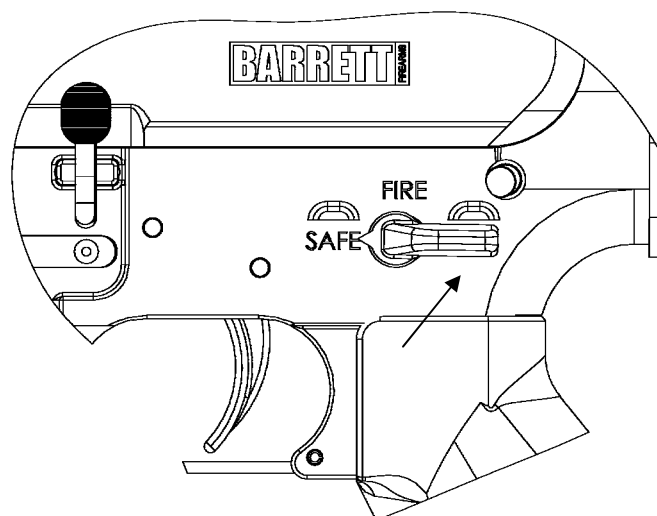

Figure 13.

DISASSEMBLY AND ASSEMBLY

This rifle disassembles into two primary assemblies:

1. The upper assembly (Figure 14).

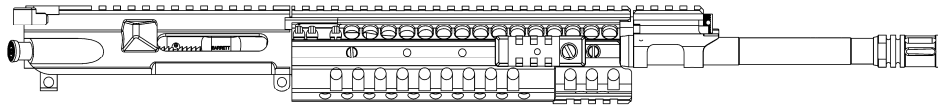

Figure 14.

2. The lower assembly (Figure 15).

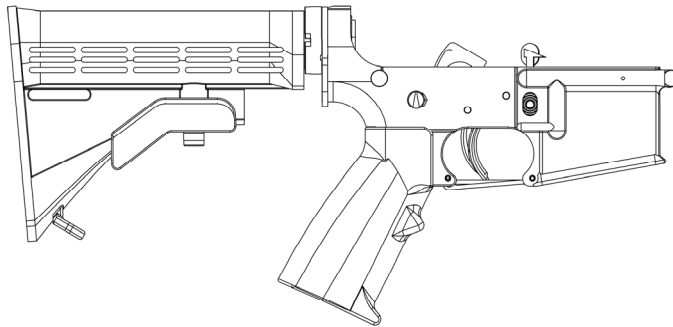

Figure 15.

Separating the Upper and Lower Receivers

1. Ensure rifle is unloaded and clear by following the steps in the previous section. With the safety on and bolt closed (Figure 16), push the takedown pin (rearward most pin) until it clears its detent then pull it until it stops. Push the pivot pin (forward most pin) until it clears its detent then pull it until it stops. (Figure 17). Separate the upper and lower receivers.

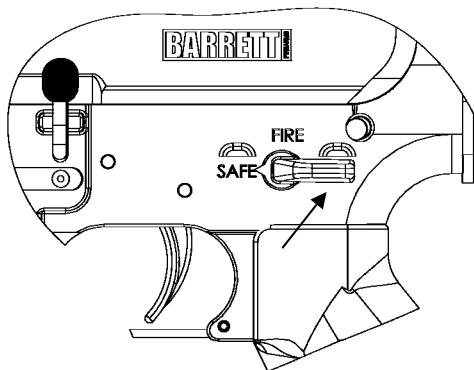

Figure 16

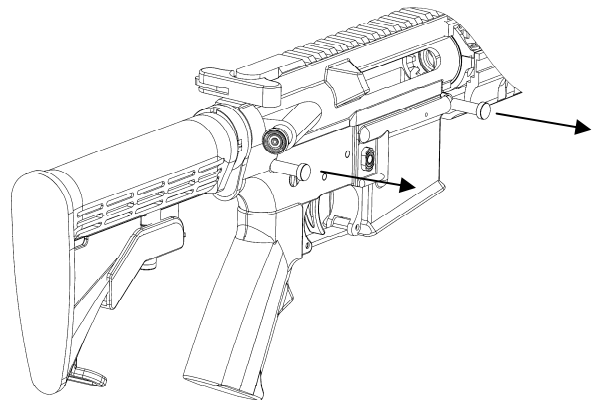

Figure 17

DISASSEMBLY OF UPPER RECEIVER COMPONENTS

1. On a work surface, turn the upper receiver upside down. Pull back the charging handle and withdraw the bolt carrier assembly. (Figure 18).

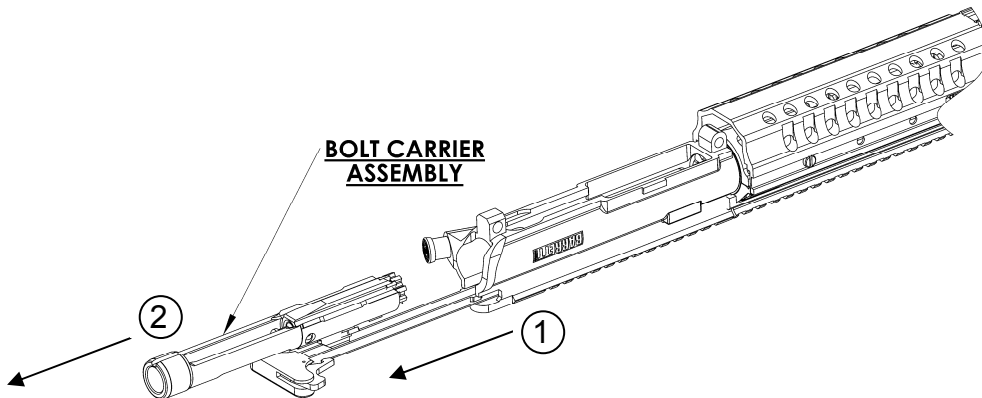

Figure 18.

2. Next, lift the charging handle out of its track and remove it. (Figure 19).

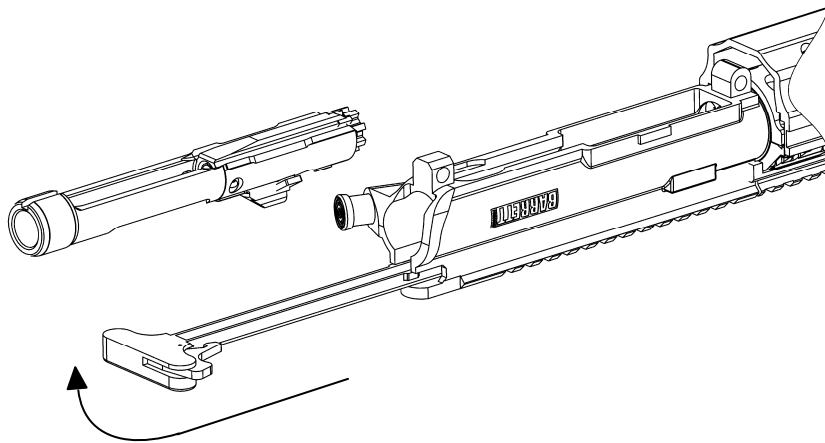

Figure 19.

DISASSEMBLY OF THE BOLT CARRIER ASSEMBLY

1. Remove the firing pin retaining pin by pushing it through until it can be gripped and pulled out. Remove the firing pin by sliding it out of the rear of the bolt assembly. Remove the cam pin by lifting up. Pull the bolt assembly from the bolt carrier. (Figure 20).

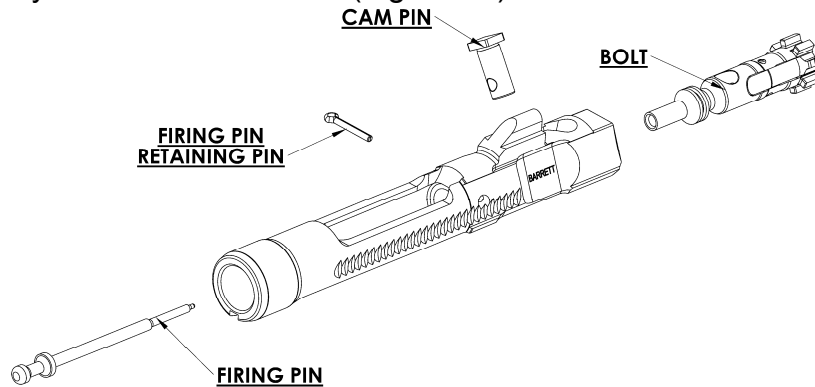

Figure 20. Bolt Carrier Assembly

DISASSEMBLY OF THE BOLT

Note

Disassemble the extractor and spring assembly only when dirty or damaged.

1. Use a pin punch to remove the extractor pin. (Figure 21). Applying pressure to extractor will aid in removal of extractor pin. Be aware that the extractor spring and extractor are in tension.
2. Remove the extractor and spring. (Figure 22).

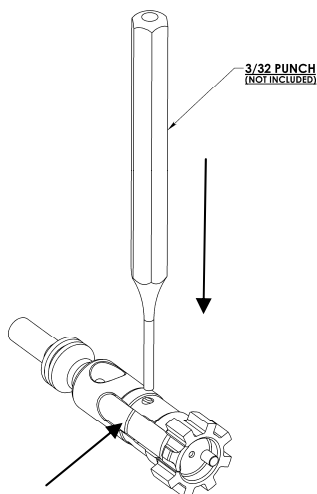

Figure 21.

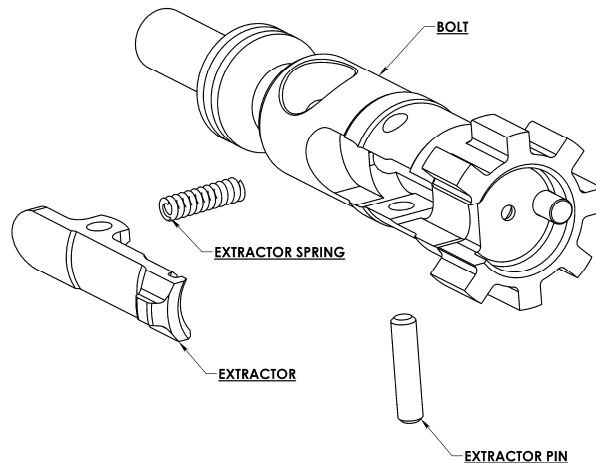

Figure 22.

Note

Bolt and extractor illustrated here may not reflect your configuration.

DISASSEMBLY OF PISTON SYSTEM

Note

Disassemble the gas piston and spring assembly only when dirty or damaged.

1. Depress gas plug detent. Rotate gas plug until plug notch aligns with gas block shoulder. (Figure 23.)

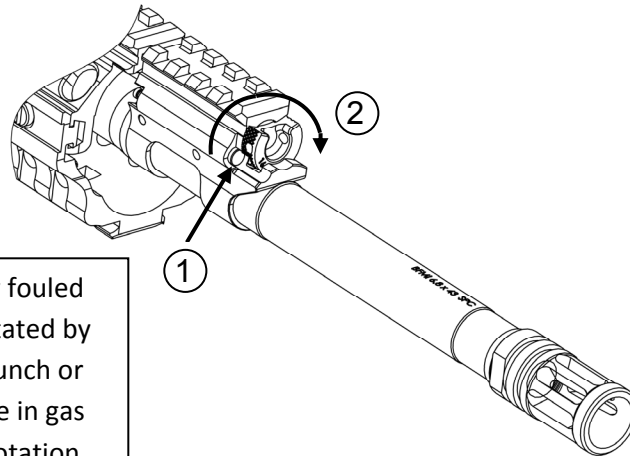

If gas plug is heavily fouled and unable to be rotated by hand, insert 3/32 punch or similar tool into hole in gas plug to assist with rotation.

Figure 23.

2. Remove gas plug from gas block and tilt gun muzzle down. (Figure 24). Gas piston will fall free through front of the gas block. (Figure 25).

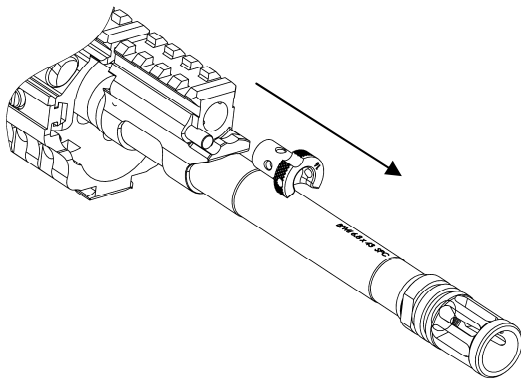

Figure 24.

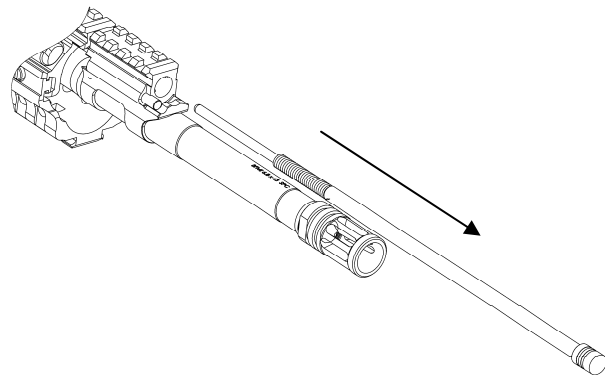

Figure 25.

Note

Gas block illustrated here may not reflect your configuration.

FRONT SIGHT OPERATION (if included)

1. To engage front sight, depress sight and slide the front sight latch rearward. (Figure 26).
2. The front sight can be moved up or down when zeroing rear sight.
3. To increase elevation (raise point of impact of bullet), insert key and turn clockwise. (Figure 27).
4. To decrease elevation (lower point of impact of bullet), insert key and turn counterclockwise. Once rear sight is zeroed, front sight post should not be moved. (Figure 27).

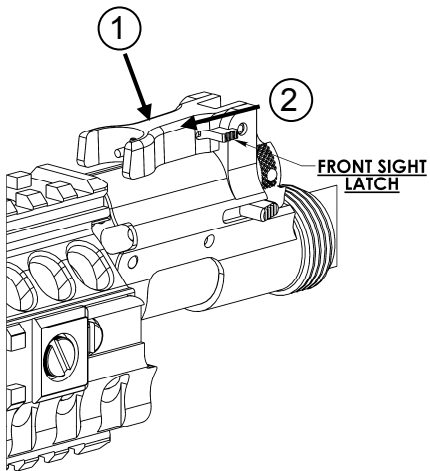

Figure 26.

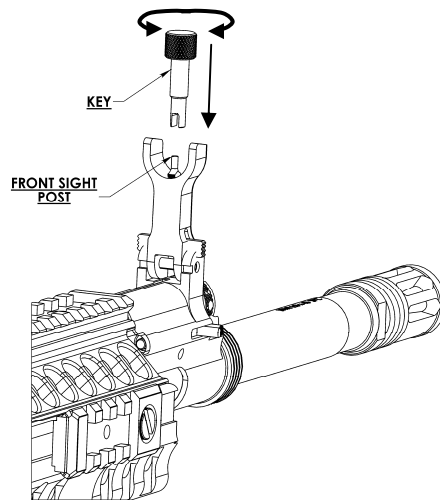

Figure 27.

REAR SIGHT OPERATION (if included)

1. The low-profile rear sight can be engaged by depressing the spring-loaded flip-up lever. (Figure 28).
2. To change horizontal point of impact of bullet, rotate windage knob located on the rear sight. This will move rear sight to left or right when zeroing. (Figure 29).
3. Rotate windage knob clockwise to move point of impact of bullet to the left. Rotate knob counterclockwise to move point of impact of bullet to the right.

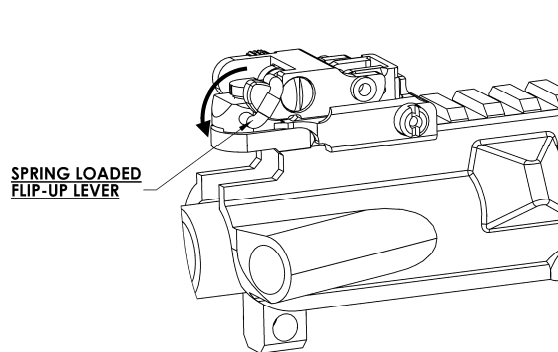

Figure 28

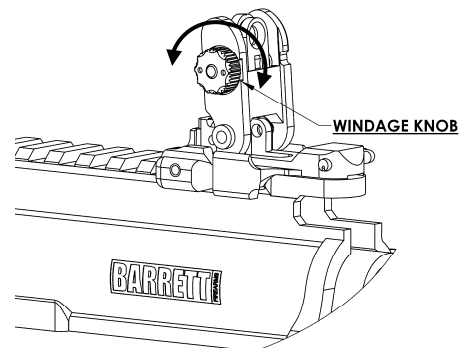

Figure 29.

REMOVAL OF HANDGUARD

1. Turn (A) screws 90° to unlock position. (Figure 30).
2. Loosen (B) screw. (Figure 30).

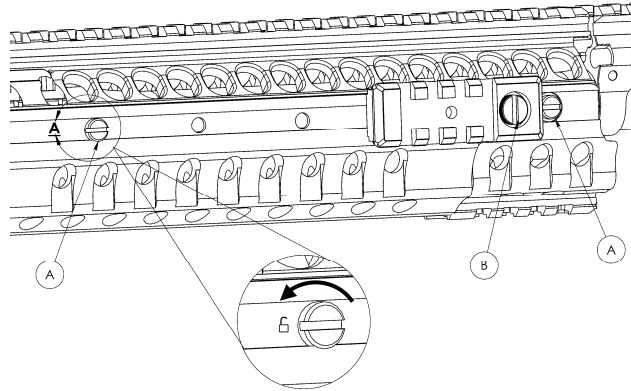

Figure 30.

3. Slide bottom half off of handguard while holding top half. (Figure 31).

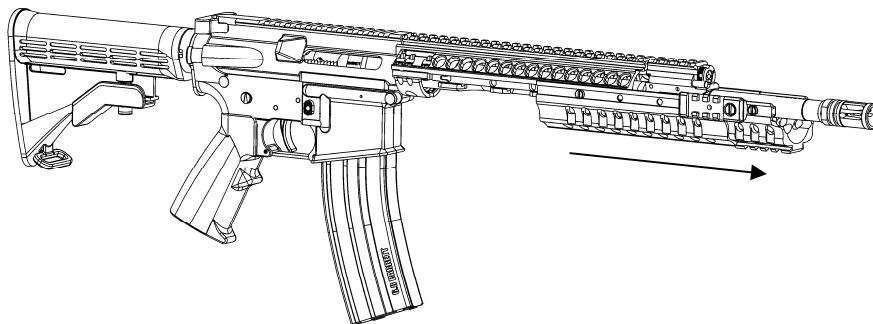

Figure 31.

DISASSEMBLY OF LOWER RECEIVER

Caution

The disassembly of trigger components should be accomplished by a qualified armorer.

Caution

The buffer is under strong spring pressure. If un-captured, it can be launched from its tube and cause injury.

Note

Do not pull trigger while lower is disassembled from the upper. The hammer will strike the bolt catch which may damage or break the bolt catch.

1. The retainer and the buffer spring must be held simultaneously in order to remove safely. (Figure 32). Push on the buffer face while holding the retainer down with another finger or a suitable tool. Carefully remove the buffer with the buffer spring. (Figure 33).

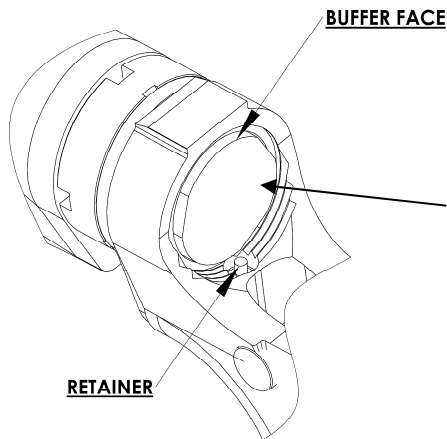

Figure 32.

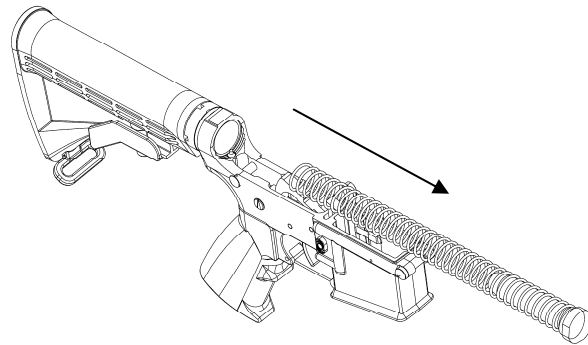

Figure 33.

CLEANING AND LUBRICATION

WARNING

Unload and clear the rifle before cleaning.

Caution

Do not insert cleaning rods through muzzle. The barrel crown could be damaged which would severely degrade the accuracy of the rifle.

Cleaning procedure

1. The rifle should be cleaned and lubricated after each shooting session. Regular cleaning prevents the corrosive effects of moisture.
2. Apply cleaning solvent to a chamber brush and clean the chamber. Barrett Heavy Bore Cleaner is recommended.
3. Apply cleaning solvent to a bore brush and clean the bore. Barrett Heavy Bore Cleaner is recommended.
4. Clean the flash hider with a stiff plastic brush and bore solvent. It is best to clean the flash hider at the same time the barrel is being cleaned as the bore solvent will help loosen carbon build-up on its interior walls.
5. Clean the bolt face with bore solvent. Use a stiff plastic brush to remove carbon from both the extractor and the ejector. Depress the ejector and extractor by hand to test their smooth function.
6. Use dry patches as necessary to remove cleaner from the bore and chamber.
7. Clean the remainder of the rifle with cotton-tipped swabs, general purpose brushes and cleaning clothes. Make sure all metal surfaces are coated with preservative oil.

OPERATING UNDER UNUSUAL CONDITIONS

Unusual conditions are defined as any condition requiring special maintenance. Perform maintenance outlined for the climate similar to your operational area.

Extreme Cold: When operating rifle in extremely cold temperatures, clean and lubricate the rifle at room temperature if possible. Apply a light coat of temperature appropriate lubrication to all functional parts. To prevent freezing, keep rifle covered when moving from a warm to cold area. This will allow gradual cooling. Keep rifle dry. Keep ammunition dry as frozen ammo can cause malfunctions. Do not lubricate ammunition. Always keep bore free of snow. If snow gets into the bore, clean the bore before firing using a clean patch and cleaning rod.

Dust or Sand: Dust and sand can get into rifle and cause malfunctions and excessive wear. Keep rifle covered when possible. Use lubricant sparingly.

Heavy Rain and Fording Operations: Perform maintenance in accordance with normal cleaning procedures and apply thin coat of lubricant. Do not lubricate ammunition. Always drain any water from barrel prior to firing. Dry the bore with clean patch and cleaning rod.

Hot, Wet Climate: Perform maintenance more frequently. Inspect hidden surfaces for corrosion. Clean and lubricate if corrosion is found. To prevent external corrosion, remove handprints with oily cloth. Dry completely then lubricate rifle. Never store rifle in a wet carrying case.

TROUBLESHOOTING

MALFUNCTION	CAUSE	CORRECTIVE ACTION
1. Failure to feed	<ol style="list-style-type: none"> 1. Did not draw bolt carrier fully to rear 2. Magazine not seated 3. Damaged magazine 4. Improper shooter position 	<ol style="list-style-type: none"> 1. Retract bolt carrier fully to the rear. 2. Seat magazine 3. Replace or repair magazine 4. Clean and lubricate 5. Firmly shoulder the butt stock.
2. Failure to chamber	<ol style="list-style-type: none"> 1. Damaged cartridge 2. Dirty or obstructed chamber 	<ol style="list-style-type: none"> 1. Remove and replace cartridge 2. Clean chamber
3. Failure to lock or unlock	<ol style="list-style-type: none"> 1. Obstruction between firing pin and bolt. 	<ol style="list-style-type: none"> 1. Disassemble and clear obstruction.
4. Failure to fire	<ol style="list-style-type: none"> 1. Faulty ammunition. Primers dented in center of sufficient depth to fire 2. Obstructed firing pin 3. Hammer 4. Bolt not fully in battery 	<ol style="list-style-type: none"> 1. Replace ammunition 2. Disassemble and clear obstruction 3. Replace hammer or hammer spring 4. Return complete bolt assembly for repair 5. Push charge handle fully forward and/or forward assist.
5. Failure to extract	<ol style="list-style-type: none"> 1. Broken or worn extractor 2. Broken or worn extractor spring 3. Extractor not moving freely 4. Dirty ammunition or chamber 5. Broken case rim 	<ol style="list-style-type: none"> 1. Replace extractor 2. Replace extractor spring 3. Clean extractor, extractor spring, and recess 4. Clean chamber and insure ammunition is clean 5. Clear with cleaning rod.
6. Failure to eject	<ol style="list-style-type: none"> 1. Broken or worn ejector 2. Broken or worn ejector spring 3. Ejector not moving freely 	<ol style="list-style-type: none"> 1. Replace ejector 2. Replace ejector spring 3. Clean ejector, ejector spring, and recess
7. Very hard recoil	<ol style="list-style-type: none"> 1. Faulty or hot ammunition 2. Improper shooter position 	<ol style="list-style-type: none"> 1. Replace ammunition, cool if hot 2. Firmly shoulder the buttstock

(Intentionally left blank)

REC7 Parts List

PART NO.	DESC	QTY
68779-A	BUFFER ASSY	1
68780	BUFFER SPRING	1
68758	RECEIVER EXTENSION	1
68757	BUTTSTOCK	1
68772	RECEIVER EXTENSION NUT	1
68773	RECEIVER EXTENSION SPACER	1
68231	BOLT CARRIER	1
68112	CAM PIN	1
68111	FIRING PIN RETAINING PIN	1
68110	FIRING PIN	1
68701	EXTRACTOR PIN	1
68705	EJECTOR ROLL PIN	1
68704	EXTRACTOR	1
68814	EXTRACTOR SPRING	1
68813	EXTRACTOR SPRING INSERT	1
68803	BOLT	1
68706	EJECTOR SPRING	1
68707	EJECTOR	1
**	BARREL EXTENSION	1
**	BARREL	1
68240	BARREL NUT	1
**	BARREL EXTENSION PIN	1
68253	CRUSH WASHER	1
68222	FLASH HIDER	1
68050-A	CHARGING HANDLE ASSY	1
**	UPPER RECEIVER ASSY	1
**	LOWER RECEIVER	1
68730	TRIGGER PIN	2
68720	MAGAZINE CATCH BUTTON	1
68721	MAGAZINE CATCH SPRING	1
68732	TRIGGER GUARD PIVOT ROLL PIN	1
82056	SAFETY DETENT	1

PART NO.	DESC	QTY.
68714	SAFETY DETENT SPRING	1
82051-A	PISTOL GRIP	1
68736	LOCK WASHER	1
68735	PISTOL GRIP SCREW	1
68731-A	TRIGGER GUARD ASSY	1
68733	BUFFER RETAINER	1
68734	BUFFER RETAINER SPRING	1
68728	TRIGGER	1
68727	DISCONNECTOR SPRING	1
68729	TRIGGER SPRING	1
68726	DISCONNECTOR	1
68722	PIVOT PIN	1
68725	TAKEDOWN/PIVOT PIN DETENT	1
68724	TAKEDOWN/PIVOT PIN SPRING	1
68719	MAGAZINE CATCH	1
68716	BOLT CATCH ROLL PIN	1
68715	BOLT CATCH	1
68718	BOLT CATCH PLUNGER	1
68717	BOLT CATCH SPRING	1
68712	SAFETY SELECTOR LEVER	1
68711	HAMMER SPRING	1
68710	HAMMER	1
68210	GAS BLOCK PINS	2
68802	GAS PLUG DETENT	1
68212	RATCHET PAWL SPRING	1
68800	GAS BLOCK	1
68242	GAS PISTON SPRING	1
68250	GAS PISTON	1
68252	E CLIP	1
68216	PISTON CAP	1
68046-A	MAGAZINE ASSY	1
68771-A	HANDGUARD ASSY	1

ALTERNATE CONFIGURATION

PART NO.	DESC	QTY
**	DOUBLE SPRING EXTRACTOR	1
68703	EXTRACTOR SPRINGS	2
**	DOUBLE SPRING BOLT	1
68235	FRONT SIGHT POST	1
68237	FRONT SIGHT DETENT SPRING	1
68236	FRONT SIGHT DETENT	1
68234	FRONT SIGHT	1
82024	FRONT SIGHT PIN	1
68238	FRONT SIGHT LATCH	1
68239	FRONT SIGHT SPRING	1
68217	GAS BLOCK	1
68211	RATCHET PAWL	1
68251	RATCHET PAWL LEVER	1
68049-A	REAR SIGHT ASSEMBLY	1

** CONTACT BFMI FOR ASSISTANCE

ALTERNATE CONFIGURATION

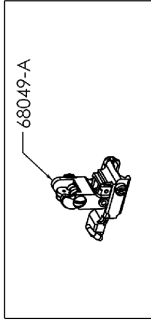

REAR SIGHT ASSEMBLY

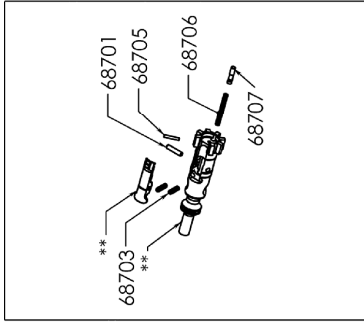

DOUBLE SPRING BOLT ASSEMBLY

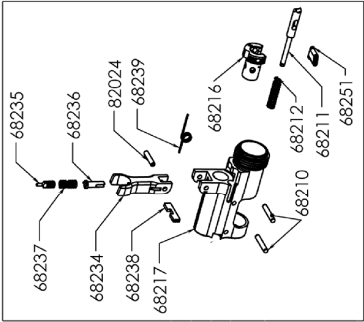

GAS BLOCK WITH FRONT SIGHT

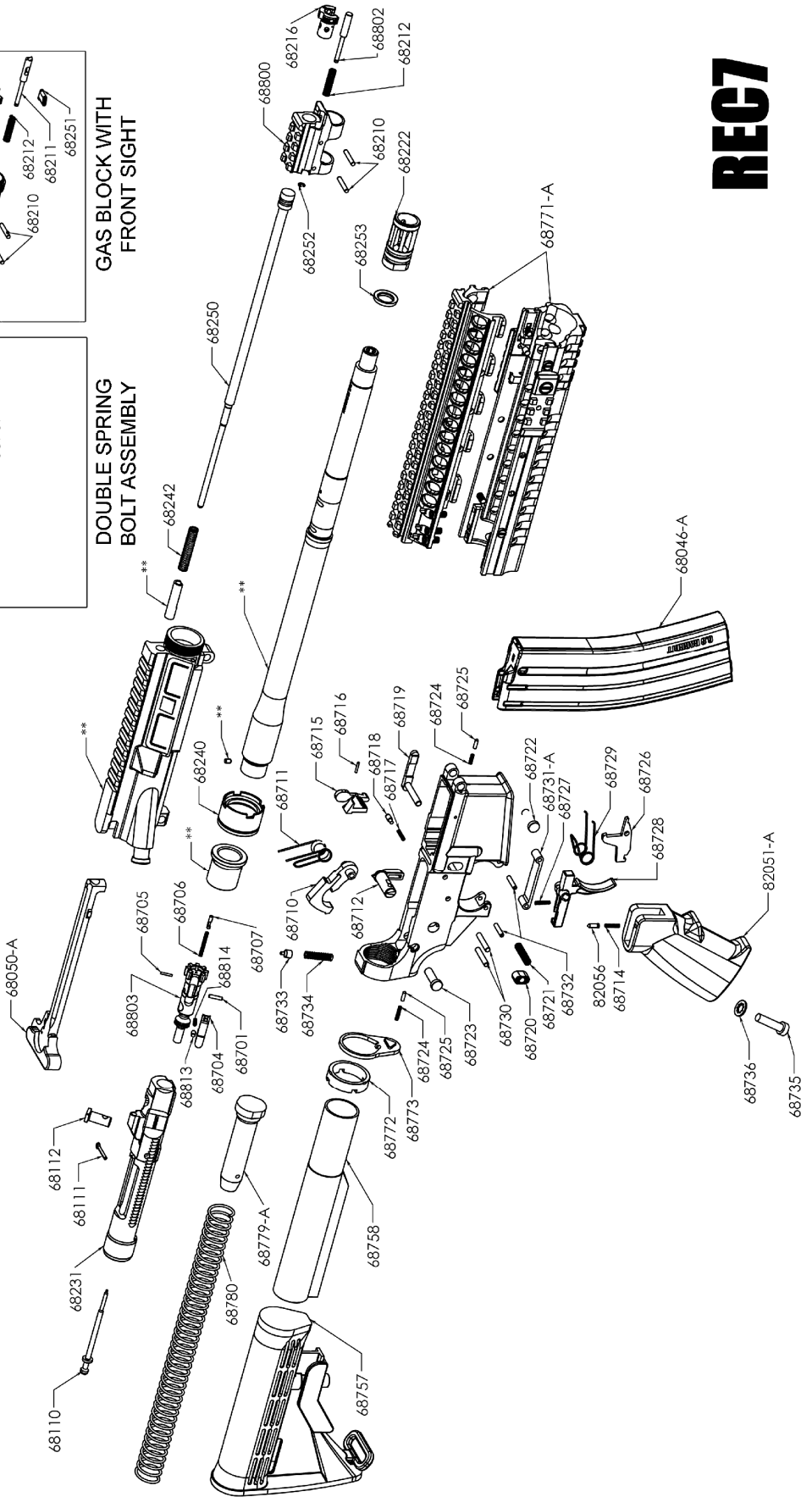

RECO7

